

String-generated quartic scalar interactions*

R. Marotta^(a) and F. Pezzella^(b)

^(a) NORDITA, Blegdamsvej 17, DK-2100 Copenhagen, Denmark

^(b) I.N.F.N. and Università di Napoli, Compl. Univ. di Monte S. Angelo, I-80126 Napoli, Italy

ABSTRACT: The *cutting and sewing* procedure is used for getting two-loop order Feynman diagrams of Φ^4 -theory with an internal $SU(N)$ symmetry group, starting from tachyon amplitudes of the open bosonic string theory. In a suitably defined field theory limit, we reproduce the field theory amplitudes properly normalized and expressed in the Schwinger parametrization.

KEYWORDS: Strings, Field Theory.

It is well-known that a string theory can provide a consistent quantum theory of gravity, unified with non-abelian gauge theories in the so-called *zero-slope limit* where the inverse string tension $\alpha' \rightarrow 0$. The reasons of such a consistency lie in the fact that this latter is a physical dimensional parameter acting as an ultraviolet cutoff in the integrals over loop momenta. Therefore it makes multiloop amplitudes free from ultraviolet divergences.

Consequently, string theory provides an alternative technique of computing field theory amplitudes. In fact, since its scattering amplitudes are organized in a very compact form, one can compute, for instance, non-abelian gauge theory amplitudes by starting from a string theory and performing the zero-slope limit, rather than using traditional field theory techniques. The expression of string amplitudes is known explicitly, including also the measure of integration on moduli space, in the case of the bosonic open string for any perturbative order [1].

These interesting features of string theory have led some authors to use it as an efficient tool to compute gluon amplitudes in Yang-Mills theory [2] ÷ [6] or graviton amplitudes in quantum gravity [7], and some improvements have been achieved in understanding the perturbative relations between gravity and gauge theory [8]. Such string-methods have also inspired some authors in developing very interesting techniques based

on the world-line path-integrals [9].

In order to derive field theory amplitudes from the corresponding string ones one has to start, for example in the case of Yang-Mills amplitudes, from a given multiloop gluon string amplitude and to single out different regions of the moduli space that, in the low-energy limit, reproduce different field theory diagrams. This program has been carried out at one-loop [10] [11] and, at this order, the five-gluon amplitude has been obtained for the first time [12].

This procedure, when extended to the two-loop case [11] [13] [14], becomes difficult to handle in the case of amplitudes with external states. The computational difficulties associated with this kind of multiloop Yang-Mills amplitudes, which are inessential for understanding the field theory limit, can be avoided if amplitudes involving scalar particles are considered. In fact, differently from what happens in gauge theories, in string theory there is not a big conceptual difference between gluon and scalar diagrams. Therefore one can get more easily from scalar amplitudes the whole information about the corners of the moduli space reproducing the known field theoretical results: these regions are exactly the ones giving the correct field theory diagrams also in the case of gluon amplitudes.

Scalar amplitudes are the ones involving tachyons of the bosonic string theory. So one can consider a slightly different zero-slope limit of the bosonic string in which only the lowest tachyonic state,

*Talk delivered by R. Marotta

with a mass satisfying $m^2 = -1/\alpha'$ is kept. In the case of tree and one-loop diagrams, this procedure is equivalent to take the zero-slope limit of an old pre-string dual model with an arbitrary value of the intercept of the Regge trajectory. It was recognized the inconsistency of this model, but the field theory limit of tree and one-loop diagrams of this pre-string dual model was shown to lead to the Feynman diagrams of Φ^3 theory [15].

In Ref. [11], it has been explicitly shown that by performing the zero-slope limit as above explained, one correctly reproduces the Feynman diagrams of Φ^3 theory, up to two-loop order.

The aim of this talk is to illustrate how the conceptual scheme pursued in Ref. [11] can be extended to two-loop amplitudes containing quartic scalar interactions. This means that, starting from string amplitudes involving tachyons, we perform on them the field theory limit in which their mass is fixed and correctly identify the corners associated to the different field theory diagrams of Φ^4 theory. Such a program is carried out by pursuing the so-called *sewing and cutting* procedure.

This work is based on the results contained in Ref. [16]. We would like to cite here the article [17] where scalar diagrams are obtained from string amplitudes through an alternative procedure based on the Schottky group properties [18].

The plan of the work is the following.

Firstly we illustrate the *sewing and cutting* procedure applying it to the four tachyon tree amplitude. We define a proper field theory limit where quartic scalar interactions are reproduced. Then we check the validity of this procedure by deriving from the two- and four-tachyon amplitudes at one-loop, respectively, the *tadpole* and the *candy* diagram of Φ^4 theory. Finally we apply it to the *double-candy* diagram.

1. Tree scalar diagrams from strings

The starting point is the planar tree scattering amplitude of four on-shell bosonic open string tachyons with momenta p_1, \dots, p_4 each satisfying the mass-shell condition $p^2 = -m^2 = \frac{1}{\alpha'}$:

$$A_4^{(0)}(p_1, p_2, p_3, p_4) = \text{Tr}[\lambda^{a_1} \lambda^{a_2} \lambda^{a_3} \lambda^{a_4}] C_0 \mathcal{N}_t^4$$

$$\times \int_0^1 dz (1-z)^{2\alpha' p_2 \cdot p_3} z^{2\alpha' p_3 \cdot p_4} \quad (1.1)$$

where the Koba-Nielsen variables relative to the tachyons labelled by 1, 2, 4 have been respectively fixed at $+\infty, 1$ and 0 .

According to the corner of moduli space where the low-energy limit of the amplitude (1.1) is performed, one can recover, for instance, Φ^3 - or Φ^4 -scalar diagrams.

In order to understand which regions in moduli space lead to the different field theory diagrams, one can use the so-called *sewing and cutting* procedure. This consists in starting from a string diagram and in cutting it in three-point vertices; next we fix the legs of each three-point vertex at $+\infty, 1$ and 0 . Then we reconnect the diagram by inserting between two three-point vertices a suitable propagator acting as a well specified projective transformation. This is chosen in such a way that its fixed points are just the Koba-Nielsen variables of the two legs that have to be sewn. The geometric role of the propagator is to identify the local coordinate systems defined around the punctures to be sewn.

The amplitude in Eq. (1.1) can be expressed also in terms of the Green functions $\mathcal{G}^{(0)}(z_i, z_j)$, defined on the world-sheet in the following way:

$$\mathcal{G}^{(0)}(z_i, z_j) = \log(z_i - z_j) \quad (1.2)$$

A necessary intermediate step for deriving tree scalar Φ^4 -diagrams is to generate tree diagrams of Φ^3 -theory. With reference to the four-tachyon tree string diagram, one can see that it can be obtained by sewing two three-point vertices as shown in Fig. (1). We sew the leg corresponding to the point 0 in the vertex at the left hand in Fig. (1a) to the leg corresponding to the point $+\infty$ in the one at the right hand through a propagator corresponding to the projective transformation

$$S(z) = Az \quad (1.3)$$

which has 0 and $+\infty$ as fixed points and the parameter A , with $0 \leq A \leq 1$, as multiplier. Performing the sewing means, in this procedure, to transform *only* the punctures of the three-point vertex at the right hand in Fig. (1a) through (1.3), hence the puncture $z_3 = 1$ transforms into

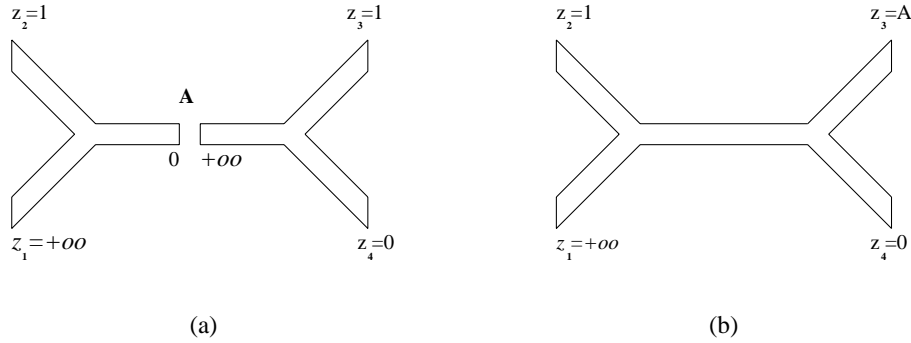

Figure 1: Sewing of two three vertices

$S(1) = A$ while the other two punctures remain unchanged.

In general, after the sewing has been performed, the Koba-Nielsen variables become functions of the parameter A appearing in the projective transformation (1.3). It is possible to give a simple geometric interpretation to this parameter, if a correspondence is established between the projective transformation in Eq. (1.3) and the string propagator, written in terms of the operator $e^{-\tau(L_0-1)}$. The latter indeed propagates an open string through imaginary time τ and creates a strip of length τ . In fact the change of variable $z = e^{-\tau}$ allows the string propagator to be written as

$$\frac{1}{L_0 - 1} = \int_0^1 dz z^{L_0 - 2} = \int_0^\infty d\tau \exp\left(-\tau\alpha' \left[p^2 + \frac{1}{\alpha'}(N-1)\right]\right) \quad (1.4)$$

and to establish the following relation between τ and A :

$$\tau = -\log A. \quad (1.5)$$

The multiplier A results to be therefore related to the length of the strip connecting two three-vertices.

On the other hand, since we want to reproduce tree Φ^3 -theory diagrams we have to consider a low-energy limit of string amplitudes in which only tachyons propagate as intermediate states. This is achieved observing from (1.4) that the only surviving contribution in the limit $\alpha' \rightarrow 0$ with $\tau\alpha'$ kept fixed is the one coming from the level $N = 0$, i.e. from tachyons with fixed mass given by $m^2 = -\frac{1}{\alpha'}$. It is obvious that this also

corresponds to the limit $\tau \rightarrow \infty$ and hence, from (1.5), to $A \rightarrow 0$. From these considerations it seems natural to introduce the variable $x = \tau\alpha'$ in terms of which the string propagator (1.4), reproduces, in the above mentioned limit, the scalar propagator

$$\frac{1}{p^2 + m^2} = \int_0^\infty dx e^{-x(p^2 + m^2)}$$

with x being interpreted as the Schwinger proper time.

From a geometrical point of view, one can imagine that the the strip connecting the two three-vertices, in this field theory limit, becomes “very long and thin”, so that only the lightest states propagate.

By rewriting the amplitude (1.1) in terms of the Schwinger parameter x or, equivalently, in terms of the multiplier A we finally get [16]:

$$A_4^{(0)} = \frac{1}{8} \text{Tr} [\lambda^{a_1} \lambda^{a_2} \lambda^{a_3} \lambda^{a_4}] \frac{g_{\phi^3}^2}{[(p_1 + p_2)^2 + m^2]} \quad (1.6)$$

where it has been used the well-known relation between g_s and g_{ϕ^3} [11]:

$$g_{\phi^3} = 16g_s(2\alpha')^{\frac{d-6}{4}}. \quad (1.7)$$

We are going now to consider a suitable limit of the string four-tachyon amplitude which can reproduce the diagram corresponding to the tree four-point vertex of Φ^4 -theory. With reference again to the Fig. (1), this diagram has to correspond to a limit in which the length of the tube connecting the two three-vertices composing the string diagram goes to zero in the limit $\alpha' \rightarrow 0$, i.e.

$$\tau = \frac{x}{\alpha'} = -\log A \rightarrow 0$$

This corresponds to the limit $A \rightarrow 1$, and hence $z \rightarrow 1$ or, equivalently, $z_3 \rightarrow z_2$.

In this limit the Green function $\mathcal{G}^{(0)}(z_2, z_3)$ is divergent. We regularize it by introducing a cut-off ϵ on the world-sheet so that

$$\lim_{z_2 \rightarrow z_3} \log[(z_2 - z_3) + \epsilon] = \log \epsilon$$

and

$$\lim_{\alpha' \rightarrow 0} \alpha' \log \epsilon = 0$$

We consider therefore the amplitude $A_4^{(0)}$ in Eq. (1.1) in the field theory limit defined by:

$$A = z = 1 - \epsilon,$$

$$\alpha' \rightarrow 0 \text{ and } x = -\alpha' \log \epsilon \rightarrow 0. \quad (1.8)$$

in which it reduces to

$$2^4 \text{Tr} [\lambda^{a_1} \lambda^{a_2} \lambda^{a_3} \lambda^{a_4}] g_s^2 (2\alpha')^{\frac{d-4}{2}}. \quad (1.9)$$

The complete amplitude is obtained by performing the sum over non cyclic permutations, finally getting a result coincident with the color ordered vertex generated by the following scalar field theory:

$$\mathcal{L} = \text{Tr} \left[\partial^\mu \phi \partial_\mu \phi + m^2 \phi^2 - \frac{g_{\phi^4}}{4!} \phi^4 \right] \quad (1.10)$$

obtaining the *matching condition*

$$g_{\phi^4} = 4g_s(2\alpha')^{d/2-2}. \quad (1.11)$$

2. One-loop Φ^4 -diagrams from strings

2.1 Tadpole diagram

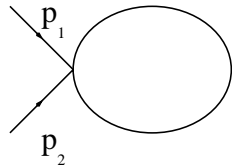

Figure 2: Tadpole

In this subsection we show how the tadpole diagram in Φ^4 -theory can be derived from string theory. The starting point will be, this time, the color ordered two-tachyon planar amplitude at one-loop:

$$\begin{aligned} A_2(p_1, p_2) &= N \text{Tr} [\lambda^{a_1} \lambda^{a_2}] C_1 \left[2g_s(2\alpha')^{\frac{d-2}{4}} \right]^2 \\ &\times \int_0^1 \frac{dk}{k^2} \left[-\frac{1}{2\pi} \log k \right]^{-\frac{d}{2}} \prod_{n=1}^{\infty} (1 - k^n)^{2-d} \\ &\times \int_k^1 \frac{dz}{z} \left[\frac{\exp \mathcal{G}^{(1)}(1, z)}{\sqrt{z}} \right]^{2\alpha' p_1 \cdot p_2}. \end{aligned} \quad (2.1)$$

We would like now to stress that if we want to reproduce diagrams of scalar field theories we have to ensure that *only* tachyon states propagate in the loops of string amplitudes. In fact this condition is fulfilled if small values of the multiplier k are considered: indeed this parameter plays exactly the same role as the multiplier A in the tree level amplitudes. Therefore an expansion in powers of k is performed keeping the most divergent terms. In so doing we get

$$\begin{aligned} A_2^{(1)}(p_1, p_2) &= \frac{N}{2} \frac{1}{(4\pi)^{d/2}} \frac{1}{(2\alpha')^{d/2}} \left[2g_s(2\alpha')^{\frac{d-2}{4}} \right]^2 \\ &\times \int_0^1 \frac{dk}{k^2} \left[-\frac{1}{2} \log k \right]^{-\frac{d}{2}} \int_k^1 \frac{dz}{z} e^{2\alpha' \mathcal{G}^{(1)}(1, z)} \end{aligned} \quad (2.2)$$

where the Green function, in the limit we are considering, is

$$\mathcal{G}^{(1)}(z_1, z_2) = \log(z_1 - z_2) - \frac{1}{2} \log z_1 z_2 + \frac{\log^2 z_1 / z_2}{2 \log k} \quad (2.3)$$

Our aim is to identify the right limit to get the tadpole diagram in Fig. (2).

Starting from two three-vertices, we sew the leg 0 with the leg $+\infty$ according to the Fig. (3).

Such a sewing is performed by considering again the projective transformation $S(z) = Az$, which has $+\infty$ and 0 as fixed points and which transforms $z_2 = 1$ in the second vertex in Fig. (3a) in the multiplier A getting the configuration shown in Fig. (3b).

The next step consists in performing a limit in which $z_2 \rightarrow z_1$, i.e. in which $A \rightarrow 1$ with $\alpha' \log(1 - A) \rightarrow 0$, as said before. In this limit we should get the tadpole diagram. Indeed we have:

$$A_2^{(1)}(p_1, p_2) = \frac{2N}{(4\pi)^{d/2}} \frac{1}{2\alpha'} g_s^2 \int_0^1 \frac{dk}{k^2} \left[-\frac{1}{2} \log k \right]^{-d/2} \quad (2.4)$$

By defining:

$$x = -\alpha' \log k$$

with $0 \leq x \leq +\infty$, we can rewrite (2.4) as follows:

$$A_2^{(1)}(p_1, p_2) = \frac{N}{(4\pi)^{d/2}} \lambda_{\phi^4} \int_0^\infty dx e^{-xm^2} x^{-d/2} \quad (2.5)$$

By using the matching condition established at the tree level (1.11) we get from string theory the tadpole diagram of Φ^4 -theory.

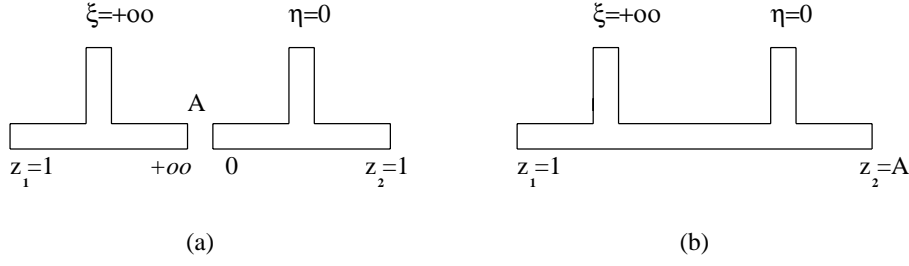

Figure 3: Sewing for the tadpole diagram

2.2 Candy diagram

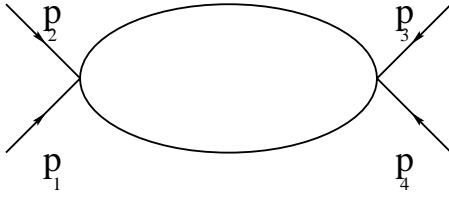

Figure 4: Candy diagram

Let us now derive the *candy* diagram from the four-tachyon one-loop amplitude:

$$\begin{aligned}
 A_4^{(1)}(p_1, p_2, p_3, p_4) &= \frac{N}{(4\pi)^{d/2}} \text{Tr} [\lambda^{a_1} \lambda^{a_2} \lambda^{a_3} \lambda^{a_4}] \\
 &\times \frac{1}{(2\alpha')^{d/2}} \left[2g_s (2\alpha')^{\frac{d-2}{4}} \right]^4 \int_0^1 \frac{dk}{k^2} \left[-\frac{1}{2} \log k \right]^{-\frac{d}{2}} \\
 &\times \int_k^1 \frac{dz_4}{z_4} \int_{z_4}^1 \frac{dz_3}{z_3} \int_{z_3}^1 \frac{dz_2}{z_2} \\
 &\prod_{i < j=1}^4 \left[\frac{\exp(\mathcal{G}(z_i, z_j))}{\sqrt{z_i z_j}} \right]^{2\alpha' p_i \cdot p_j} \quad (2.6)
 \end{aligned}$$

The diagram relative to this amplitude can be obtained by means of the sewing procedure illustrated in Fig. (5).

The four-particle vertices of the candy diagram can be generated by the corner of the moduli space where the Koba-Nielsen variables $z_1 \rightarrow z_2$ and $z_3 \rightarrow z_4$. This is performed by considering the limit in which the multipliers B_i ($i = 1, 2$) $\rightarrow 1$. We stress here that, in this limit, the Green functions $\mathcal{G}(z_1, z_2)$ and $\mathcal{G}(z_3, z_4)$ result to be divergent and we regularize them by introducing a cut-off ϵ on the world-sheet so that $B_i = 1 - \epsilon$. In this limit the length of the strips connecting the three-vertices become very short and in this way the four-particle vertices of the

diagram in consideration are generated. Furthermore, in order to select in the loop only the lightest states, we also take the limit in which the multiplier $A \rightarrow 0$, and, after having performed both the limits, we send the cut-off to zero in all the regular expressions.

From these geometrical considerations that shed light on the different roles played by the multipliers A -like and B -like, we select the following corner of the moduli space reproducing the candy diagram of Φ^4 -theory:

$$A \rightarrow 0 \quad B_i = 1 - \epsilon \rightarrow 1 \quad (2.7)$$

Let us now evaluate the amplitude (2.2) in the corner (2.7).

The first step consists in rewriting, in this region of the moduli space, the measure and the integration region in the amplitude (2.2).

The ordering of the Koba-Nielsen variables determines the integration regions of the multipliers A and B_i in terms of which the whole amplitude is expressed, after the sewing. More precisely, in the limits (2.7), one gets:

$$\begin{aligned}
 &\int_0^1 \frac{dk}{k^2} \int_k^1 \frac{dz_2}{z_2} \int_k^{z_2} \frac{dz_3}{z_3} \int_k^{z_3} \frac{dz_4}{z_4} \\
 &\simeq \int_0^1 \frac{dk}{k^2} \int_k^1 \frac{dA}{A} + O(k) \quad (2.8)
 \end{aligned}$$

For this diagram, the proper times associated to the single propagators in the loop, are identified with the Schwinger parameters

$$t_1 = -\alpha' \log k/A \quad t_2 = -\alpha' \log A \quad (2.9)$$

where k has to be understood as the proper time of the whole loop.

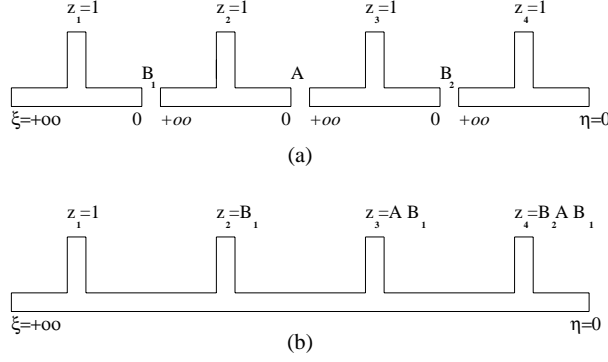

Figure 5: Sewing for the candy diagram

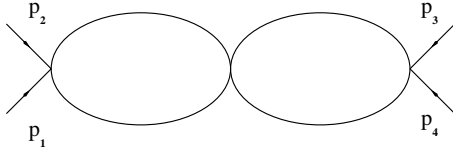

Figure 6: Double-candy

The Green functions defined in (2.3), in this limit, drastically simplify.

In particular the Green function $2\alpha' \mathcal{G}(z_1, z_3)$, when written in terms of the Schwinger parameters, becomes

$$2\alpha' \mathcal{G}(z_1, z_3) = t_2 - \frac{t_2^2}{t_1 + t_2}. \quad (2.10)$$

By expressing the full amplitude in terms of t_1 and t_2 one gets:

$$A_4 = \frac{N}{(4\pi)^{d/2}} \frac{1}{2} d^{a_1 a_2 l} d^{a_3 a_4 l} [2^6 g_s^4 (2\alpha')^{d-4}] \times \int_0^\infty dt_1 \int_0^\infty dt_2 (t_1 + t_2)^{-d/2} e^{-m^2(t_1+t_2)} \times e^{-(p_1+p_2)^2 \left[t_2 - \frac{t_2^2}{t_1+t_2} \right]} \quad (2.11)$$

Once again we have the right result in field theory by using the matching condition (1.11).

3. A two-loop diagram: double-candy

In this section we show how to get the *double-candy* diagram of Φ^4 theory, Fig. (6), starting from the two-loop four-tachyon amplitude in bosonic string theory:

$$A_4^{(2)}(p_1 p_2 p_3 p_4) = N^2 Tr [\lambda^{a_1} \lambda^{a_2} \lambda^{a_3} \lambda^{a_4}] C_2 N_0^4$$

$$\times \int [dm]_2^4 \prod_{i < j} \left[\frac{\exp \mathcal{G}^{(2)}(z_i, z_j)}{\sqrt{V_i'(0) V_j'(0)}} \right]^{2\alpha' p_i \cdot p_j} \quad (3.1)$$

where the expressions for $V_i'(0)$ are given by:

$$(V_i'(0))^{-1} = \left| \frac{1}{z_i - \rho_a} - \frac{1}{z_i - \rho_b} \right| \quad (3.2)$$

with ρ_a and ρ_b depending on the position of z_i and being the two fixed points on the left and on the right hand of z_i .

We expand the previous amplitude for small values of the multipliers k_μ keeping the most divergent contribution that is the one corresponding to the tachyon state and again the Green functions reduce to the following form [11]:

$$\mathcal{G}^{(2)}(z_i, z_j) = \log(z_i - z_j) + \frac{\log^2 T \log k_2 + \log^2 U \log k_1 - 2 \log T \log U \log S}{2(\log k_1 \log k_2 - \log^2 S)} \quad (3.3)$$

with

$$S = \frac{(\eta_1 - \eta_2)(\xi_1 - \xi_2)}{(\xi_1 - \eta_2)(\eta_1 - \xi_2)} \\ T = \frac{(z_j - \eta_1)(z_i - \xi_1)}{(z_j - \xi_1)(z_i - \eta_1)} \\ U = \frac{(z_j - \eta_2)(z_i - \xi_2)}{(z_i - \eta_2)(z_j - \xi_2)} \quad (3.4)$$

The measure, once used the projective invariance to fix $z_4 = 1$, $\xi_2 = +\infty$ and $\eta_2 = 0$, becomes:

$$[dm]_2^4 = \prod_{i=1}^3 \frac{dz_i}{V_i'(0)} \prod_{\mu=1}^2 \frac{dk_\mu}{k_\mu^2} \frac{d\xi_1 d\eta_1}{(\xi_1 - \eta_1)^2}$$

$$\times [\det(-i\tau_{\mu\nu})]^{-d/2} \quad (3.5)$$

where $\tau_{\mu\nu}$ is the period matrix in the limit of small multipliers [16].

Let us now identify the corner of the moduli space that, in the field theory limit, reproduces the two-loop candy diagram, according to our procedure. In Fig. (8) it is shown the final configuration that we reach applying the sewing procedure with the following projective transformations:

$$S_i = B_i z \quad \hat{S}_1 = A_1 z \quad \hat{S}_2 = A_2 z \quad (3.6)$$

with $i = 1, 2, 3$.

Once the sewing procedure is completed, the Koba-Nielsen variables and the moduli of the surface, are expressed in terms of the multiplier of the transformations according the correspondence shown in Fig. (8).

If we want to obtain the four-particle vertices peculiar of the two-loop candy diagram, we have to take in consideration the corner of the Koba-Nielsen variables characterized by $z_1 \rightarrow z_2$, $z_3 \rightarrow z_4$ and by the modulo $\xi_1 \rightarrow 1$. This configuration is achieved considering the limits in which $B_i \rightarrow 1$ and introducing the suitable regularizers, when necessary.

Furthermore, considering also the limit $A_i \rightarrow 0$, we select scalar particles in the other internal legs.

The corner of moduli space reproducing the Φ^4 scalar diagram illustrated in Fig.(6) is

$$A_i \rightarrow 0 \quad B_i = 1 - \epsilon \quad (3.7)$$

Let us now evaluate the amplitude (3.1) in this corner.

The Green functions (3.3) are then evaluated in the limit (3.7) where they take a simple form and the same is done for the local coordinates $V'_i(0)$ and for the measure.

As regards the integration region, we observe that the sewing procedure determines an ordering of the Koba-Nielsen variables and of the fixed points as shown in Fig. (8).

In the field theory limit (3.7) we integrate the multipliers B -like between 0 and 1 and the multipliers A -like, between 0 and δ being δ , a positive infinitesimal quantity.

The Schwinger parameters in this case are related to the A_i 's by the following relations [11]:

$$t_{i+2} = -\alpha' \log A_i, t_1 = -\alpha' \log \frac{k_1}{A_2}, t_2 = -\alpha' \log \frac{k_2}{A_1} \quad (3.8)$$

with $i = 1, 2$.

Rewriting the Green functions and the measure in terms of the Schwinger parameters we get:

$$\begin{aligned} A_4^{(2)}(p_1 \cdots p_4) &= \frac{N^2}{(4\pi)^2} d^{a_1 a_2 l} d^{a_3 a_4 l} \\ &\times \frac{\left[2^4 g_s^2 (2\alpha')^{\frac{d-4}{2}}\right]^3}{2^5} \int_0^\infty \prod_{i=1}^4 dt_i e^{-m^2(t_1+t_2+t_3+t_4)} \\ &\times (t_1+t_4)^{-d/2} (t_2+t_3)^{-d/2} \\ &\times e^{-(p_1+p_2)^2 \left[\frac{t_1 t_4}{t_1+t_4} + \frac{t_2 t_3}{t_2+t_3}\right]} \end{aligned} \quad (3.9)$$

where a sum over inequivalent permutations of the external particles has been done analogously as in the one-loop candy-diagram case.

Now using the matching condition (1.11), we get the same result, including the overall factor, as the one obtained in field theory.

In conclusion, we have used the *sewing and cutting* procedure in order to show how Φ^4 -theory diagrams can be reproduced from string amplitudes, up to two loop-order. The whole information so obtained can be in principle extendible to Yang-Mills diagrams involving quartic interactions.

Acknowledgments

We would like to thank P. Di Vecchia, A. Frizzo, L. Magnea, R. Russo and M.G. Schmidt for helpful discussions.

R.M. and F.P. thank respectively Università di Napoli and NORDITA for their kind hospitality during different stages of their work.

References

- [1] See, for example, P. Di Vecchia, *Multiloop amplitudes in string theory* in Erice, *Theor. Phys.* (1992), and references therein.
- [2] Z. Bern and D.A. Kosower, *Nucl. Phys.* **B379** (1992) 451.

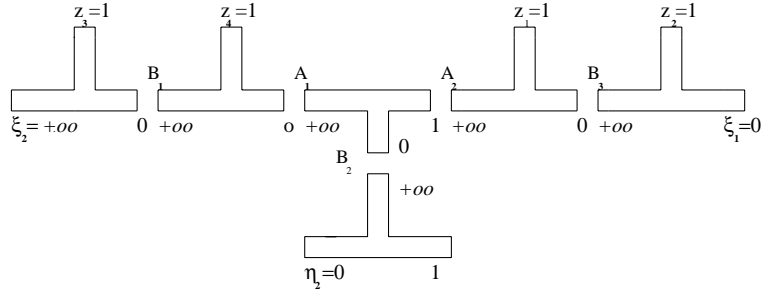

Figure 7: Sewing of the two-loop candy diagram

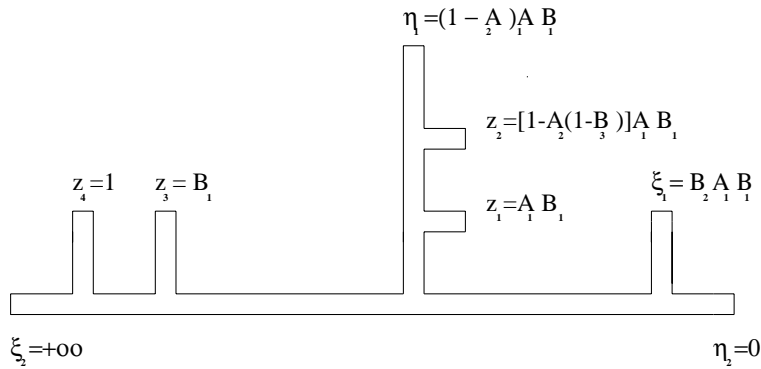

Figure 8: Sewing configuration for the two-loop candy diagram

- [3] R. R. Metsaev and A.A.Tseytlin, *Nucl. Phys.* **B298** (1988) 109.
- [4] Z. Bern, *Phys. Lett.* **296 B** (1992) 85.
- [5] Z. Bern and D.C. Dunbar, *Nucl. Phys.* **B379** (1992) 562.
- [6] P. Di Vecchia, L. Magnea, A. Lerda, R. Russo and R. Marotta, *Nucl. Phys.* **B469** (1996) 235, [hep-th/9601143](#).
- [7] Z. Bern, D.C. Dunbar and T. Shimada, *Phys. Lett.* **B312** (1993) 277.
- [8] Z. Bern, L. Dixon, D.C. Dunbar, M. Perelstein and J.S. Rozowsky, *Nucl. Phys.* **B530** (1998) 401, [hep-th/9811140](#).
- [9] H.T. Sato and M.G. Schmidt, *World-line approach to the Bern-Kosower formalism in two-loop Yang-Mills theory*, [hep-th/9812229](#).
- [10] Z. Bern, L. Dixon and D.A. Kosower, *Ann. Rev. Nucl. Part. Sci.* **46** (1996) 109, [hep-ph/9602280](#).
- [11] P. Di Vecchia, L. Magnea, A. Lerda, R. Marotta and R. Russo, *Phys. Lett.* **B388** (1996) 65, [hep-th/9607141](#).
- [12] Z. Bern, L. Dixon and D.A. Kosower, *Phys. Rev. Lett.* **70** (1993) 2677.
- [13] L. Magnea and R. Russo, *Two-loop gluon diagrams from string theory*, [hep-ph/9706396](#), talk presented at DIS 97, Chicago.
- [14] Z. Bern, J.S. Rozowsky and B. Yan, [hep-ph/9702424](#).
- [15] J. Scherk, *Nucl. Phys.* **B31** (1971) 222.
- [16] R. Marotta and F. Pezzella, *Two-Loop Φ^4 -Diagrams from String Theory*, [hep-th/9912158](#), to be published in *Phys. Rev. D*
- [17] A. Frizzo, L. Magnea and R. Russo, *Scalar field theory limits of bosonic string amplitudes*, [hep-th/9912183](#).
- [18] P. Di Vecchia, F. Pezzella, M. Frau, K. Hornfeck, A. Lerda and S. Sciuto, *Nucl. Phys.* **B322** (1989) 123.