

Nuclear Astrophysics @ GANIL

Francois de Oliveira*

GANIL, Bd H. Becquerel, 14000 Caen

E-mail: oliveira@ganil.fr

GANIL is an unique facility where high quality radioactive beams are available at low and intermediate energies. A presentation is made of the experimental nuclear astrophysics program undertaken at GANIL using these beams.

XIII Nuclei in the Cosmos,

7-11 July, 2014

Debrecen, Hungary

*On behalf of the different "astro" collaborations: E561S, E563, E578S, E568S, E641S, NAVI and my colleagues from GANIL: B. Bastin, F. Boulay, J.C. Dalouzy, P. Delahaye, B. Jacquot, G. Randisi, A. Sanchez, O. Sorlin, P. Ujjic *et al*

1. GANIL beams

GANIL accelerators can produce stable, fragmented in-flight and post-accelerated radioactive beams in the range of energies from 1.2 AMeV to 95 AMeV depending on the element. Light and medium mass radioactive beams can be produced at the LISE magnetic spectrometer in the 10-50 AMeV energy range by the fragmentation of primary stable beams, e.g. ^{60}Fe was produced at 27 AMeV with 10^5 pps and 70% purity. At GANIL, the ISOL technique is also employed in the SPIRAL1 facility to produce and to post-accelerate radioactive beams (He, N, O, F, Ne, Ar, Kr) from 1.2 AMeV up to 25 AMeV, e.g. ^{18}F was produced with 2×10^4 pps and 97% purity, ^{19}Ne with 5×10^7 pps and 100% purity. New SPIRAL1 beams (Si, P, S, Cl...) are under development using a Febiad source and are expected for 2017. In the future, more beam production systems will be available. The new Super Separator Spectrometer (S3) will be available after 2018 at the SPIRAL2 facility. It can be used to produce by fusion evaporation reactions and to select condensable elements, e.g. ^{45}V at 1-2 AMeV with 10^5 pps (calculated). The NFS (Neutron For Science) facility will produce in 2016 high energy neutrons in the 1-40 MeV energy range. The phase 2 of SPIRAL2 could be built in 2025 if the decision is taken soon. Fission fragments, e.g. ^{132}Sn , could be post-accelerated to energies 1-10 AMeV, perfect for transfer reaction measurements. With SPIRAL2 phase 2, it will be also possible to produce very intense radioactive beams of light elements, e.g. ^{18}F with 10^7 pps. These beams could be produced by transfer reactions induced on different targets using the very intense primary beams available at SPIRAL2. Many of these beams are of high interest in nuclear astrophysics. So, the nuclear astrophysics community is called to support the phase 2 of SPIRAL2.

With the advent of intense radioactive beams, new opportunities have opened in nuclear astrophysics. In the following, several examples of studies performed at GANIL are presented in order to illustrate this activity.

2. Inelastic scattering

The observation of γ rays from novae ejecta should provide a rather direct way to investigate nucleosynthesis and matter ejection mechanism. The γ -ray spectrum produced in novae is predicted to peak at 511 keV, originating from positron annihilations. It was shown that the main contribution to positrons production is the long-lived ^{18}F radioactive nucleus (half-life 109.77 min). Therefore, the amount of radiation emitted scales with the ^{18}F content of the nova ejecta, which in turn depends strongly on its production and destruction rates. The reaction $^{18}\text{F}(p,\alpha)^{15}\text{O}$ was identified to be the most sensitive and uncertain for the destruction of ^{18}F in novae [1]. A better understanding of the spectroscopy of the compound nucleus, ^{19}Ne , mainly the above-proton-emission-threshold states, is highly needed. Recent studies suggest that several important states located just above the proton emission threshold may have uncorrect spin assignments.

A new experiment (E641S B. Bastin *et al.*) was proposed at GANIL to investigate the spectroscopy of ^{19}Ne . The inelastic scattering reaction $\text{H}(^{19}\text{Ne},p')^{19}\text{Ne}^*$ was used to populate excited states in ^{19}Ne . The scattered protons p' were selected and measured with the VAMOS magnetic spectrometer. Coincidences with proton p'' or α particles emitted from $^{19}\text{Ne}^*$ were observed with a DSSSD located just behind the target, see Fig.1 (a). Analysis of the particle-particle angular

correlation can be used to constrain spin and parity of the states [2] and branching ratios. These properties will be used to determine the rate of the $^{18}\text{F}(p,\alpha)^{15}\text{O}$ and $^{18}\text{F}(p,\gamma)^{19}\text{Ne}$ reactions. This experiment is under analysis, preliminary results can be seen in Fig.1 (b), and final results are expected very soon [3].

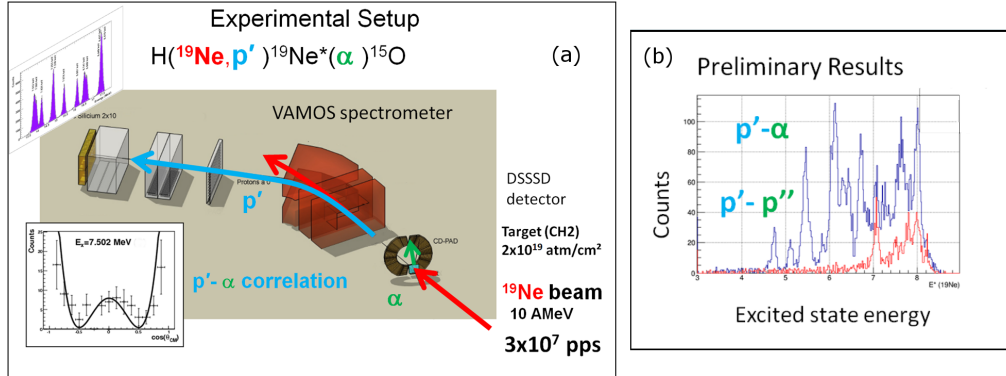

Figure 1: (a) Schematic view of the experimental setup. The intense beam of ^{19}Ne impinging on a plastic target, the scattered protons were selected and measured with the VAMOS magnetic spectrometer. Particles emitted from excited states in $^{19}\text{Ne}^*$ were detected with the "CD-PAD" telescope of silicon detectors. The angular distributions of these particles will be used to constrain the spin and parity of the states in ^{19}Ne . (b) Preliminary results. Proton spectrum conditioned with the detection of a proton or an α in the DSSSD detector. The particle emission thresholds in ^{19}Ne are $S_{\alpha} = 3.53$ MeV and $S_p = 6.41$ MeV.

3. Resonant Elastic Scattering and Direct measurements of cross section

The same astrophysical question was approached in a different way. The main objective of the E561S experiment (A. Murphy *et al* [4], The School of Physics and Astronomy Edinburgh UK) was to confirm the existence of a new $1/2+$ state predicted and observed earlier above the proton emission threshold [2]. The cross sections of the two reactions $\text{H}(^{18}\text{F},\alpha)^{15}\text{O}$ and $\text{H}(^{18}\text{F},p)^{18}\text{F}$ were measured simultaneously in inverse kinematics using a ^{18}F radioactive beam produced by the SPIRAL1 facility and accelerated to 4 AMeV. It was the first time that a direct measurement of cross section was performed at low energy at GANIL. An important part of the work was made in order to develop this new beam of ^{18}F at low energy and with a high purity. It was obtained with an intensity of 2×10^4 pps and a purity of 97%. A $6 \mu\text{m}$ thick foil of gold was used to degrade the energy of the beam down to about 2.3 AMeV and a polyethylene target of about $50 \mu\text{m}$ thick was used to induce reactions. Scattered protons and emitted alpha particles were detected with a DSSSD silicon detector placed at forward angles (180° in the center of mass frame) within a total angular acceptance of about 10° (lab). Protons and alpha particles were identified using their energy and time-of-flight. A stable beam of ^{18}O was also used in the same experimental conditions for calibrations. The results of this experiment confirm the existence, the energy and width of the broad $1/2+$ resonance [4]. Several experiment of resonant elastic scattering were performed at GANIL during the last decade [5, 6, 7]. It was demonstrated that it is possible to achieve with this method and the SPIRAL1 post-accelerated beams an energy resolution better than 5 keV in CM.

Direct measurement of radiative α -capture reactions at low energy is also needed in astrophysics in the problem of the origin of the p-nuclei. We have started an experimental project in order to measure some of these important reactions in inverse kinematics with the LISE velocity filter. The Wien filter of LISE is the biggest velocity filter in the world, making it a good opportunity for this kind of measurement (E563, Harissopoulos *et al*). We tried to use a helium implanted solid target [8], and we work on the building of a windowless helium gas target.

4. Transfer reactions

Transfer reactions were also used at GANIL to study the spectroscopy of exotic nuclei and to solve some astrophysical puzzles. For example, large $^{48}\text{Ca}/^{46}\text{Ca}$ ratios were observed in certain refractory inclusions of meteorites. A transfer experiment was proposed at GANIL in order to investigate these mysterious isotopic anomalies [9]. A plausible astrophysical scenario to account for the overabundance of ^{48}Ca is the r-process. The neutron-rich stable $^{46,48}\text{Ca}$ isotopes are produced during a neutron-capture and β -decay process. The main contribution to the production of these Ca isotopes is provided by the β -decay of their progenitor isobars in the Ar isotopic chain. This study aimed to deduce radiative neutron capture rate in ^{47}Ar from the spectroscopic information obtained through $d(^{46}\text{Ar}, ^{47}\text{Ar})p$ transfer reaction using a 2×10^4 pps ^{46}Ar radioactive beam produced by the SPIRAL1 facility and accelerated to 10 AMeV. The protons corresponding to a neutron pick-up on bound or unbound states in ^{47}Ar nuclei were detected at backward angles by the position-sensitive Si array-detector MUST. The transfer like ejectiles were detected in the SPEG magnetic spectrometer. Level scheme, spin assignments and spectroscopic factors were deduced for ^{47}Ar , and then used to deduce the rate of the $^{46}\text{Ar}(n, \gamma)^{47}\text{Ar}$ reaction. It was shown that a neutron density of about $3 \times 10^{21} \text{cm}^{-3}$, that is a weak rapid neutron capture process, favors the neutron capture reaction in comparison to the β -decay of ^{46}Ar . At the same neutron density, the calculated neutron capture on ^{48}Ar is longer than beta decay time of ^{48}Ar . Consequently the neutron capture is halted in the Ar chain at $A = 48$, accumulating substantial amount of ^{48}Ca . Conversely, few depletion occurs through β -decay of ^{46}Ar . These two features can account for explaining the observed high $^{48}\text{Ca}/^{46}\text{Ca}$ ratio [9].

5. Beta decay studies and electron screening effect

The cross section of nuclear reactions between charged particles is enhanced at sub-Coulomb energies because of the electron screening. Electron screening can also induce a change in the half-life of radioactive nuclei. In the case of the β -decay, the half-life is dictated by the law: $\log ft = \text{constant}$. The Fermi function "f" is sensitive to the presence of electrons, inducing a change in the partial half-life "t". It is predicted longer half-life for β^- decays, and shorter one for the β^+ decays. An experiment was performed at GANIL by P. Ujic *et al* [7] in order to investigate for the first time this screening effect within a superconductor material. A foil of Niobium was cooled down to different temperatures, down to 4 K. Niobium is a normal metallic conductor at room temperature, and it becomes superconductor at temperatures lower than 9.2 K. In the superconducting phase, free-electrons couple to make quasi-bosons Cooper pairs. Two pure beams of radioactive ions, $^{19}\text{O}(\beta^-)$ and $^{19}\text{Ne}(\beta^+)$, were produced with the SPIRAL1 facility with about

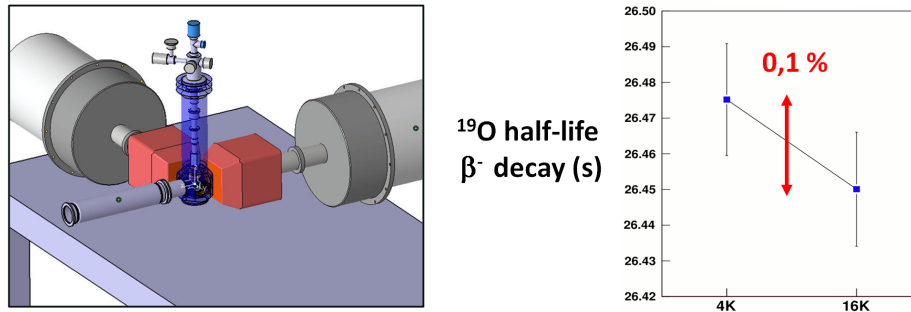

Figure 2: Left: A schematic view of the experimental setup. Beta decays were measured with a plastic scintillator and two EXOGAM gamma detectors. Right: Half-life of ^{19}O was measured at 4K and 16K. No significant difference was observed.

10^5 pps and 6 AMeV. Simulations showed that accumulation of lattice damages produced by the beam was not sufficient to destroy the superconducting phase during the experiment. Ions were implanted in the foil in cycles of implantation / decay phases. The foil was located inside a cryostat surrounded by two EXOGAM germanium clovers detectors and one plastic detector located in a compact geometry, see Fig. 2. Decay lifetimes were measured with an accuracy better than 0.1%. Cycles of measurements performed at different temperatures were used in order to reduce the systematic errors. We observed that half-lives and branching ratios measured in the two phases are consistent within a 1σ error bar. This measurement casts strong doubts on the predicted strong electron screening in a superconductor. The measured difference in screening energy is 110(90) eV for ^{19}Ne and 400(320) eV for ^{19}O . Accurate determinations of the half-lives were obtained for ^{19}O : 26.476(9) s, and for ^{19}Ne : 17.254(5) s [10].

6. Conclusion and Outlook

GANIL is proposing unique and high quality beams, including post-accelerated radioactive beams. Moreover, state-of-the-art detectors and equipments are available: high acceptance magnetic spectrometer VAMOS, high selection zero degree spectrometer LISE, gamma spectrometer EXOGAM and AGATA, active target ACTAR... As it was shown in this short review, different kinds of experimental techniques: e.g. inelastic scattering, resonant elastic scattering, transfer reactions and direct measurements, were used to improve our knowledge on several astrophysical phenomena. In the future, the same techniques will be used for other cases. Several letters of intent were proposed and these demonstrate that GANIL is hosting an exciting program of experimental nuclear astrophysics. This program includes: direct measurements of cross sections of p-nuclei performed in inverse kinematics using the Wien Filter of LISE or S3, transfer reactions with the new SPIRAL1 beams, resonant elastic scattering reactions using the active target ACTAR, time reverse reactions with radioactive beams, DSAM with AGATA etc. Ideas for new experiments are very welcome. We thank the different collaborations for their contribution to this beautiful program, in particular the Helmholtz Virtuelle Institute NAVI.

References

- [1] A. Coc, M. Hernanz, J. José and J.-P. Thibaud, *Astron. Astrophys.*, **357**, 561 (2000).
- [2] J.C. Dalouzy *et al.*, *Phys. Rev. Lett.* **102**, 162503 (2009).
- [3] F. Boulay, Ph.D. thesis. Université de Caen, France. To be submitted in 2015.
- [4] D. J. Mountford et al *Phys. Rev. C* **85**, 02280 (2012).
- [5] F. de Oliveira Santos *et al.*, *Eur. Phys. J. A* **24**, 237 (2005).
- [6] M. Assie *et al.*, *Phys. Let. B* **712**, 198 (2012).
- [7] I. Stefan *et al.*, *Phys. Rev. C* **90**, 014307 (2014).
- [8] P. Ujic, Ph.D. thesis. Université de Caen, France, (2011).
- [9] L. Gaudefroy *et al.*, *Eur. Phys. J. A* **27**, 309(2006)
- [10] P. Ujic et al., *Phys. Rev. Lett.* **110**, 032501 (2013).