

# Design of the High Voltage Supply Module of a Prototype Energy Spectrometer for Solar Wind Plasma Measurement

**Di Yang<sup>1</sup>**

*Department of Modern Physics, University of Science and Technology of China  
State Key Laboratory of Particel Detection and Electronics(IHEP-USTC)  
Hefei, 230026, China  
E-mail: dyg87@mail.ustc.edu.cn*

**Zhe CAO**

*Department of Modern Physics, University of Science and Technology of China  
State Key Laboratory of Particel Detection and Electronics(IHEP-USTC)  
Hefei, 230026, China  
E-mail: caozhe@ustc.edu.cn*

**Xi QIN**

*Department of Modern Physics, University of Science and Technology of China  
State Key Laboratory of Particel Detection and Electronics(IHEP-USTC)  
Hefei, 230026, China  
E-mail: qinxi630@mail.ustc.edu.cn*

**Xinjun HAO**

*Division of Space Physics, University of Science and Technology of China  
CAS Key Laboratory of Geospace Environment  
Hefei, 230026, China  
E-mail: xjhao@ustc.edu.cn*

**Shubin LIU**

*Department of Modern Physics, University of Science and Technology of China  
State Key Laboratory of Particel Detection and Electronics(IHEP-USTC)  
Hefei, 230026, China  
E-mail: liushb@ustc.edu.cn*

**Changqing FENG\***

*Department of Modern Physics, University of Science and Technology of China  
State Key Laboratory of Particel Detection and Electronics(IHEP-USTC)  
Hefei, 230026, China  
E-mail: fengcq@ustc.edu.cn*

**Qi An**

*Department of Modern Physics, University of Science and Technology of China  
State Key Laboratory of Particel Detection and Electronics(IHEP-USTC)  
Hefei, 230026, China  
E-mail: anqi@ustc.edu.cn*

---

<sup>1</sup>Speaker; \*Corresponding Author

**Abstract:** A prototype energy spectrometer is being developed for space missions aiming at observing solar wind plasma activity. This detector mainly consists of three sections: entrance section, particle detection section and readout electronics. The entrance section is implemented by a symmetrical quadrispherical Electrostatic analyzer (ESA) with a top hat, which selects incident particles with their incoming direction and by their energy per charge (E/Q) value. And the detection section is composed of two microchannel plate (MCP) electron multipliers and position encoding discrete anodes. A fast sweeping high voltage (HV) with 32 steps in 62.5 ms and sweep range from -2300 V to -5 V for ESA, and a fixed HV at -2500 V to -2300 V for the MCPs, are needed by this detector. In order to meet the requirement of HV supply of the ESA and the MCP, a HV supply module is designed in this paper. Firstly a HV module is employed to generate a -3000 V fixed output, which is divided by a resistor divider to get the fixed HV. Meanwhile, it is sent to a fast HV Optocoupler to generate the sweeping HV. Test results show that less than 0.8% relative precision for the fixed HV, 0.7% integral nonlinearity (INL) with fast enough slew rate (0.8 V/us) for the sweeping HV, are attained, which indicates that the high voltage supply module meets the design requirements. The module has been successfully assembled with the prototype detector for ground-based vacuum test.

**Keywords:** Solar wind plasma, Energy spectrometer detector, High voltage supply, Optocoupler

## 1 Introduction

Currently, different space-borne instrumentation based on various measurement principles has been employed to study plasma for planetary space missions [1]. For in situ sensing mission, the energy spectrometer is a useful instrument to measure charged particles energy information, for example, the Hot Ion analyzer (HIA) in the Cluster Ion Spectrometry experiment, the Plasma and Suprathermal Ion Composition (PLASTIC) detector on the STEREO Observatories etc [2, 3].

An energy spectrometer detector is being developed for plasma measurement aiming at observing solar wind activity. This energy spectrometer detector contains three structural elements: Entrance System (Energy/charge Analyzer), particle detection system, and detector electronics.

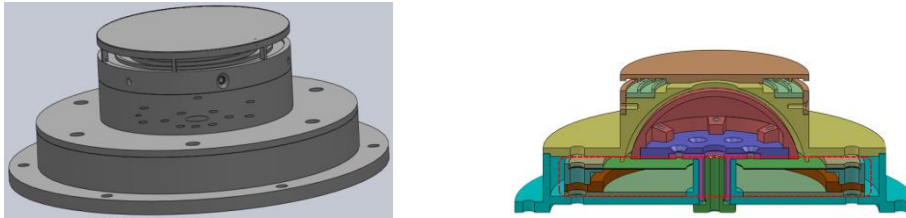

Fig. 1 architecture of the ESA

The Energy/charge Analyzer is implemented by a symmetrical ESA with a top hat. And the detection system mainly consists of two MCP electron multipliers in a chevron pair configuration and position encoding discrete anodes. The architecture of the ESA is shown in Fig.1.

Incident particles with certain energy-per-charge ( $E/Q$ ) value and their incoming direction are selected by the ESA and then interact with two-stage MCPs, producing initial electrons and multiplying electrons with a gain factor about  $10^7$ . The signal wiring and power supply of MCPs is shown in Fig.2 [4].

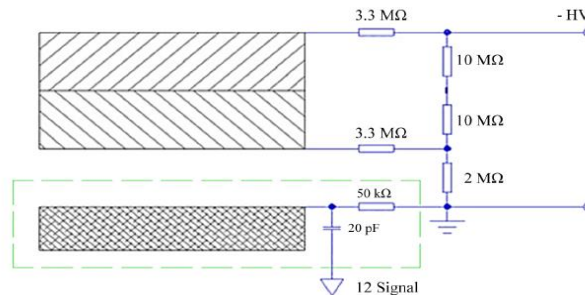

Fig. 2 the signal wiring and power supply of MCPs

High voltage is needed for both the ESA and the MCP. A sweeping HV is required to apply on the inner plate of ESA (the outer plate at ground potential) and a fixed HV on the MCP. For a sweeping HV, the higher slew rate is, the shorter the transition time from one sweep step to next sweep step is, which reduces the mistaken counts and promotes accurate measurement. However, such a module that one channel outputs a fixed high voltage and another channel outputs a fast sweeping HV with large range is seldom existed. One way to settle this problem is that two HV modules are used with one generating a fixed HV and another producing a sweeping HV. But a problem in this way is that general HV modules can barely directly output a high voltage with ramp rate up to a few volts per microsecond, which lowers the performance of the ESA [5]. And another unfavorable aspect for space mission is creasing weight and volume.

In this paper, to achieve the demand of high voltage supply for the detector, an artful HV supply module based on a high voltage optocoupler and an accuracy HV module is designed. It realizes two types of output :a sweeping HV output and a fixed HV output.

## 2 HV supply module design

According to the scientific requirements, the detector needs a fixed high voltage supply to polarize MCPs at -2500 V~-2300 V and a sweeping HV supply applied on the inner plate of the electrostatic analyzer between -2300 V and -5 V to cover a 30 eV~20 keV energy range for ions. And the sweeping HV should cover 32 energy steps within 62.5 ms (1/32 of one spin) and the sweeping energy range can be adjusted according to the mode of operation. To obtain a fixed HV, an accuracy HV module with shielding measures is utilized. To realize a sweeping HV, a fast high voltage optocoupler is employed as a high speed control element to produce high voltage with high slew rate [6].

A scheme including a Digital-to-Analog Converter (DAC), two amplifiers, a high voltage optocoupler, a HV module, an Analog-to-Digital Converter (ADC) and some voltage-proof resistors, is adopted for the high voltage supply solution. Also, an Electron-Magnetic Interference (EMI) filter is added to reduce interference. A DC-DC regulator and an LDO regulator are used to provide operating voltage for high voltage module and components. Fig.3 shows the simplified diagram of the high voltage supply module. The individual electronics elements are discussed in detail below.

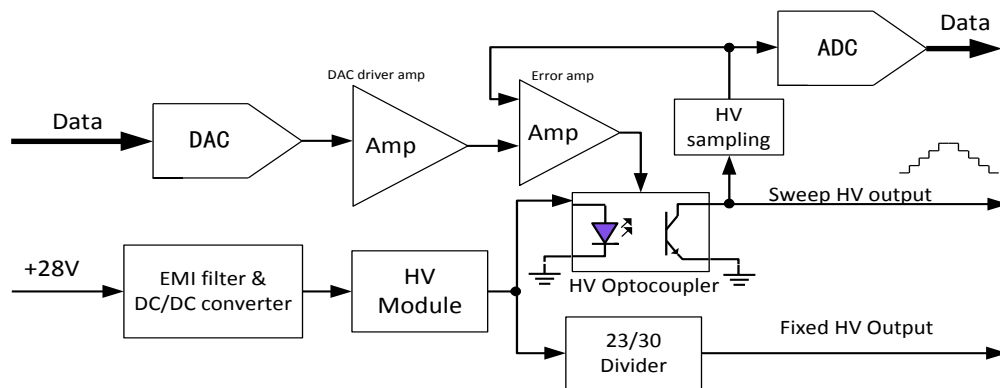

Fig. 3 the high voltage supply module diagram

### 2.1 DAC and Amplifier

The DAC converts the digital control signals from external input into an analog signal which is then conditioned to a suitable amplitude by a DAC driver amplifier. The error amplifier magnifies the error signal between the DAC driver output and the sampling circuit output. A fast 12bit DAC (DAC8412) and a rail-to-rail input-output amplifier (LM6142) are cascaded to produce the control signal for the high voltage optocoupler, which features low power dissipation, high slew rate and large dynamic range. A profit is that the LM6142 is a dual amplifiers chip, which means one amplifier is used as the DAC driver amplifier and another used as the error amplifier, thus decreasing layout region for printed circuit board (PCB).

### 2.2 HV optocoupler

The HV optocoupler is the critical component for producing a sweeping HV. It performs a linear control and outputs a sweeping HV with fast slew rate. An AmptekHV801 is preferred as a control element for its ideal performance such as high breakdown voltage, low leakage current, fast slew rate (typically 100 V/us with a 10 pF load), wide range of high voltage and so on [7]. To

achieve the large dynamic range from -2300 V to -5 V as well as a fine linearity control, the current-limiting resistance between the error amplifier output and the HV module input should be calculated based on the nominal threshold voltage and the current transfer ratio which is a function of temperature. A 270  $\Omega$  resistor is confirmed in this supply module.

### 2.3 HV module

An accuracy HV module DW-N302-1A74 (output DC  $\sim$  -3 kV), produced by DONGWEN Inc., is utilized to cover the sweep range and also is feasible for the MCP supply because of its high driving capacity. The HV module needs a clean and precise input voltage to promote linearity control. While the signal to noise ratio of the error amplifier (LM6124) that outputs control signal will fail obviously on the condition of inputting a fast signal when the supply power is disturbed. So a clean and stable power supply circuit that consists of an EMI filter, a DC-DC converter and a regulator is designed.

### 2.4 HV sampling circuit and ADC

The HV sampling circuit is composed of voltage-proof resistors and an amplifier (TLE2074) that conducts the sampling signal conditioning, feeds back to the error amplifier and outputs to the ADC. A 16-bit ADC is used to acquire the sweeping HV sampling signal and output to the signal process module. A high voltage divider made up of voltage-proof resistors is designed for the MCP working potential. And high voltage cables are used for the wiring between the HV supply module and the ESA as well as the MCP.

## 3 Test Results

Fig. 4 (left) shows the connection of ESA and HVsupply module. Fig. 4 (right) shows the HV supply module under test. The test system consists of a power supply, a remote PC, an HV module, a signal process module, a quadrispherical ESA, a high voltage meter and an oscilloscope. A control program based on Labview is developed to transmit control command to signal process module to produce high voltage control code for the HV module, the high voltage meter is used to display high voltage value and the oscilloscope is to capture and measure output wave.

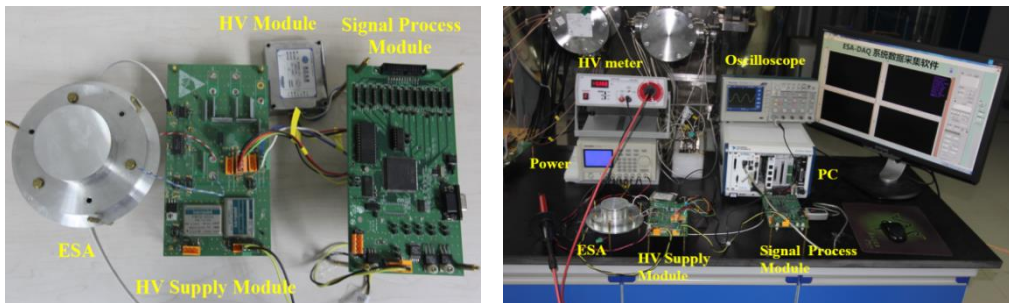

Fig. 4 ESA and HVsupply module (left); the HV supply module under test (right)

### 3.1 Sweep high voltage test

Linear sweep test is done by sending 32 sweep step commands covering -5 V to -2300 V for the ESA. Fig. 5 shows the result of correlation between the step values from tested value and ideal value. The integral nonlinearity (INL) of sweep steps reaches 0.696%.

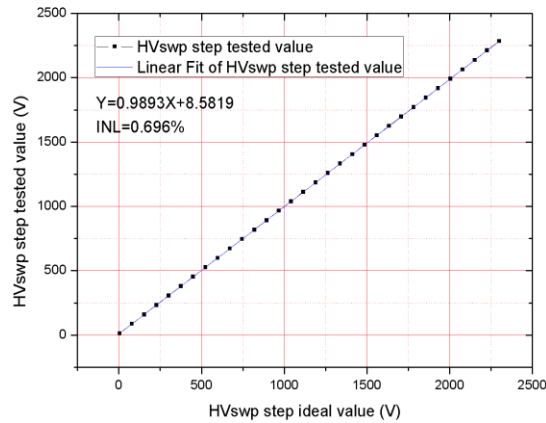

Fig. 5 Correlation between tested step values and ideal step values.

Fig. 6 (left) shows the wave of sampling signal of the sweeping HV, captured by LeCroy WavePro 715Zi oscilloscope. Fig. 6 (right) presents the time interval between adjacent steps, from which the slew rate of sweep HV can be calculated, about 0.8 V/us with 52 pF capacitance of the ESA.

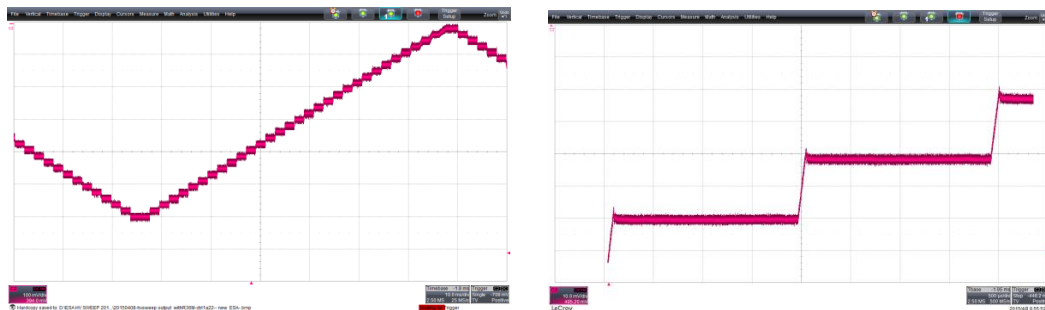

Fig. 6 wave of sampling signal of sweep HV (left); time interval between adjacent steps (right)

### 3.2 Fixed high voltage test

Fig. 7 (left) shows the result of the fixed HV deviation with 32 linear steps voltage of the ESA (step up and down), which is tested by sending different step commands (no sweep command) to adjust the potential between the inner plate and the outer plate of the ESA time and time. The maximum deviation value is about 3 V. Fig. 7 (right) shows the ripple voltage measurement by oscilloscope (2 V/div vertically and 100 ms/div horizontally) with the ESA under sweep status though a 470 pF voltage-proof capacitor and the 1 M $\Omega$  input resistance of the oscilloscope. The maximal peak-peak amplitude in 5k times captures is about 11 V. The total error caused by ESA high voltage is about 10 V, which is less than 0.8% relative precision for the fixed HV.

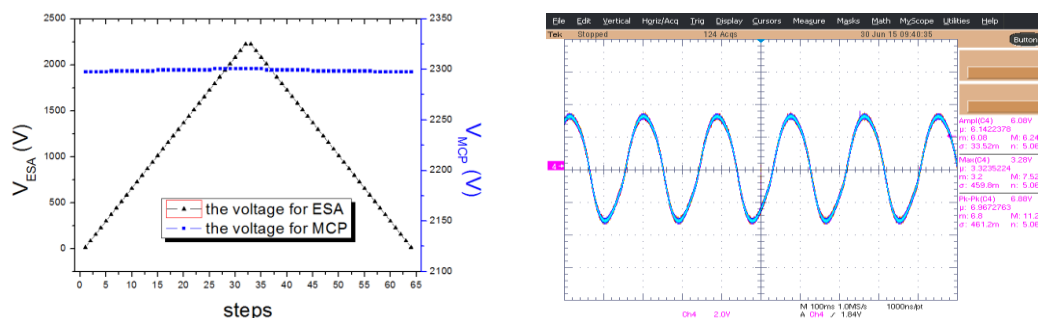

Fig. 7 fixed HV deviation with 32 linear steps voltage (left); fixed HV ripple measurement (right)

#### 4 Conclusion

A high voltage supply module has been designed to meet the requirement of high voltage supply of a prototype energy spectrometer for solar wind plasma measurement. Primary test has been completed and shows that the high voltage supply module has a good performance and satisfies the requirements of the energy spectrometer. Right now this module has been successfully assembled with the prototype detector for ground-based vacuum test.

#### Acknowledgments

This project is supported by the National Natural Science Foundation of China (Grant No. 41327802). And it is also supported by the Fundamental Research Funds for the Central Universities (WK2030040066).

#### References

- [1] Hutchinson, Ian H. Principles of plasma diagnostics. Cambridge university press, 2005.
- [2] Reme H, Aoustin C, Bosqued J M, et al. First multispacecraft ion measurements in and near the Earth's magnetosphere with the identical Cluster ion spectrometry (CIS) experiment[C]//Annales Geophysicae. Copernicus GmbH, 1999, 19(10/12): 1303-1354.
- [3] A.B. Galvin L.M. Kistler etc. The Plasma and Suprathermal Ion Composition (PLASTIC) Investigation on the STEREO Observatories. Space Sci Rev (2008) 136: 437–486.
- [4] Yufeng Shi. Development and Calibration of Space Low Energy Ion Spectrometer. University of Science and Technology of China, 2014.
- [5] Akchurin N, Atramentov O, Dimitrov L, et al. High voltage system for the CMS forward calorimeter[J]. Nuclear Instruments and Methods in Physics Research Section A: Accelerators, Spectrometers, Detectors and Associated Equipment, 2007, 572(2): 618-623.
- [6] Dave Curtis.MAVEN STATIC Sweep HVPS Technical Note on Achieving a Large Dynamic Range Sweep Supply.2008
- [7] High Voltage Optocoupler HV801 datasheet Rev D5. <http://www.amptek.com/pdf/hv801.pdf>

POS ( ICRG2015 ) 219