

## An introduction to extra dimensions and string phenomenology

---

### I. Antoniadis\*

*LPTHE, Sorbonne Universités, CNRS UMR 7589, UPMC Paris 6, 4 place Jussieu, F-75005 Paris and Albert Einstein Center, ITP, Bern University, Sidlerstrasse 5, CH-3012 Bern*  
E-mail: [ignatios.antoniadis@upmc.fr](mailto:ignatios.antoniadis@upmc.fr)

I give a short introduction to string phenomenology. In particular, I discuss the physics of extra dimensions and low scale gravity that are motivated from the problem of mass hierarchy, providing an alternative to low energy supersymmetry. I describe their realization in type I string theory with D-branes and I present the main experimental predictions in particle accelerators and their implications in cosmology.

*Proceedings of the Corfu Summer Institute 2015 "School and Workshops on Elementary Particle Physics and Gravity"*  
1-27 September 2015  
Corfu, Greece

---

\*Speaker.

## 1. Introduction

During the last few decades, physics beyond the Standard Model (SM) was guided from the problem of mass hierarchy. This can be formulated as the question of why gravity appears to us so weak compared to the other three known fundamental interactions corresponding to the electromagnetic, weak and strong nuclear forces. Indeed, gravitational interactions are suppressed by a very high energy scale, the Planck mass  $M_P \sim 10^{19}$  GeV, associated to a length  $l_P \sim 10^{-35}$  m, where they are expected to become important. In a quantum theory, the hierarchy implies a severe fine tuning of the fundamental parameters in more than 30 decimal places in order to keep the masses of elementary particles at their observed values. The reason is that quantum radiative corrections to all masses generated by the Higgs vacuum expectation value (VEV) are proportional to the ultraviolet cutoff which in the presence of gravity is fixed by the Planck mass. As a result, all masses are “attracted” to become about  $10^{16}$  times heavier than their observed values.

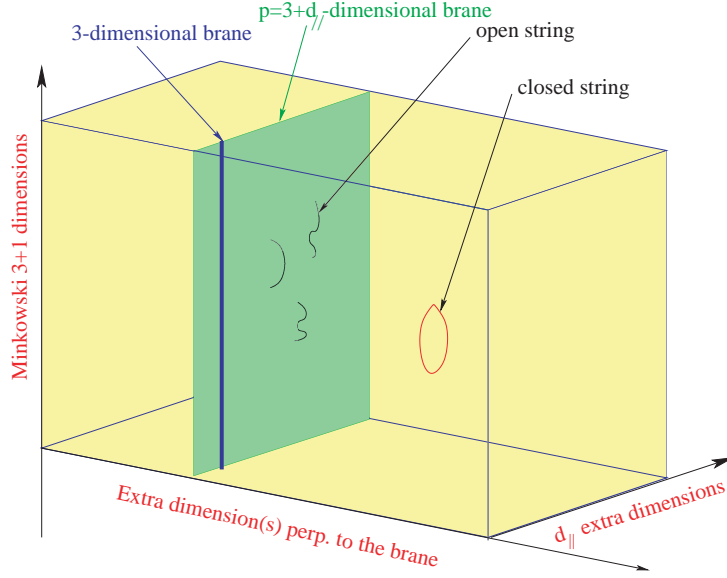
Besides compositeness, there are two main ideas that have been proposed and studied extensively during the last decades, corresponding to different approaches of dealing with the mass hierarchy problem. (1) Low energy supersymmetry with all superparticle masses in the TeV region. Indeed, in the limit of exact supersymmetry, quadratically divergent corrections to the Higgs self-energy are exactly cancelled, while in the softly broken case, they are cutoff by the supersymmetry breaking mass splittings. (2) TeV scale strings, in which quadratic divergences are cutoff by the string scale and low energy supersymmetry is not needed. Both ideas are experimentally testable at high-energy particle colliders and in particular at LHC. Below, I discuss their implementation in string theory.

The appropriate and most convenient framework for low energy supersymmetry and grand unification is the perturbative heterotic string. Indeed, in this theory, gravity and gauge interactions have the same origin, as massless modes of the closed heterotic string, and they are unified at the string scale  $M_s$ . As a result, the Planck mass  $M_P$  is predicted to be proportional to  $M_s$ :

$$M_P = M_s/g, \quad (1.1)$$

where  $g$  is the gauge coupling. In the simplest constructions all gauge couplings are the same at the string scale, given by the four-dimensional (4d) string coupling, and thus no grand unified group is needed for unification. In our conventions  $\alpha_{\text{GUT}} = g^2 \simeq 0.04$ , leading to a discrepancy between the string and grand unification scale  $M_{\text{GUT}}$  by almost two orders of magnitude. Explaining this gap introduces in general new parameters or a new scale, and the predictive power is essentially lost. This is the main defect of this framework, which remains though an open and interesting possibility [1].

The other idea has as natural framework of realization type I string theory with D-branes. Unlike in the heterotic string, gauge and gravitational interactions have now different origin. The latter are described again by closed strings, while the former emerge as excitations of open strings with endpoints confined on D-branes [2]. This leads to a braneworld description of our universe, which should be localized on a hypersurface, i.e. a membrane extended in  $p$  spatial dimensions, called  $p$ -brane (see Fig. 1). Closed strings propagate in all nine dimensions of string theory: in those extended along the  $p$ -brane, called parallel, as well as in the transverse ones. On the contrary, open strings are attached on the  $p$ -brane. Obviously, our  $p$ -brane world must have at least the three



**Figure 1:** In the type I string framework, our Universe contains, besides the three known spatial dimensions (denoted by a single blue line), some extra dimensions ( $d_{\parallel} = p - 3$ ) parallel to our world  $p$ -brane (green plane) where endpoints of open strings are confined, as well as some transverse dimensions (yellow space) where only gravity described by closed strings can propagate.

known dimensions of space. But it may contain more: the extra  $d_{\parallel} = p - 3$  parallel dimensions must have a finite size, in order to be unobservable at present energies, and can be as large as  $\text{TeV}^{-1} \sim 10^{-18} \text{ m}$  [3]. On the other hand, transverse dimensions interact with us only gravitationally and experimental bounds are much weaker: their size should be less than about 0.1 mm [4].

## 2. Framework of low scale strings

In type I theory, the different origin of gauge and gravitational interactions implies that the relation between the Planck and string scales is not linear as (1.1) of the heterotic string. The requirement that string theory should be weakly coupled, constrain the size of all parallel dimensions to be of order of the string length, while transverse dimensions remain unrestricted. Assuming an isotropic transverse space of  $n = 9 - p$  compact dimensions of common radius  $R_{\perp}$ , one finds:

$$M_P^2 = \frac{1}{g_s^4} M_s^{2+n} R_{\perp}^n, \quad g_s \simeq g^2. \quad (2.1)$$

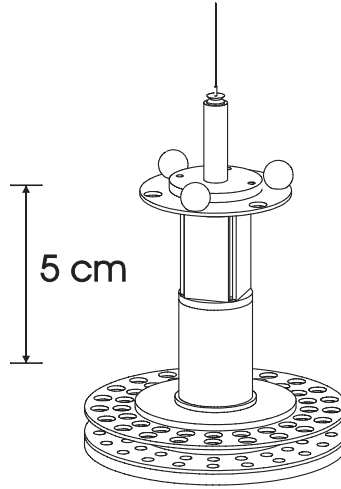
where  $g_s$  is the string coupling. It follows that the type I string scale can be chosen hierarchically smaller than the Planck mass at the expense of introducing extra large transverse dimensions felt only by gravity, while keeping the string coupling small [5]. The weakness of 4d gravity compared to gauge interactions (ratio  $M_W/M_P$ ) is then attributed to the largeness of the transverse space  $R_{\perp}$  compared to the string length  $l_s = M_s^{-1}$ .

An important property of these models is that gravity becomes effectively  $(4 + n)$ -dimensional with a strength comparable to those of gauge interactions at the string scale. The first relation of

Eq. (2.1) can be understood as a consequence of the  $(4+n)$ -dimensional Gauss law for gravity, with

$$M_*^{(4+n)} = M_s^{2+n}/g^4 \quad (2.2)$$

the effective scale of gravity in  $4+n$  dimensions. Taking  $M_s \simeq 1$  TeV, one finds a size for the extra dimensions  $R_\perp$  varying from  $10^8$  km, .1 mm, down to a Fermi for  $n = 1, 2$ , or 6 large dimensions, respectively. This shows that while  $n = 1$  is excluded,  $n \geq 2$  is allowed by present experimental bounds on gravitational forces [4, 6]. Thus, in these models, gravity appears to us very weak at macroscopic scales because its intensity is spread in the “hidden” extra dimensions. At distances shorter than  $R_\perp$ , it should deviate from Newton’s law, which may be possible to explore in laboratory experiments (see Fig. 2).

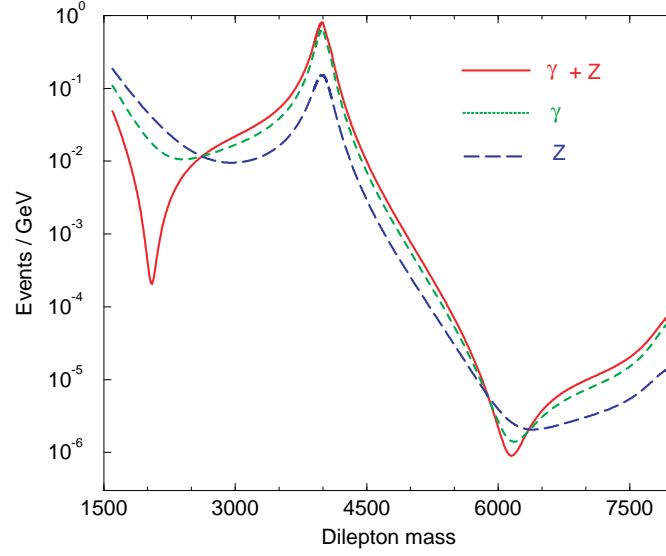


**Figure 2:** Torsion pendulum that tested Newton’s law at  $55 \mu\text{m}$ .

## 2.1 Experimental implications in accelerators

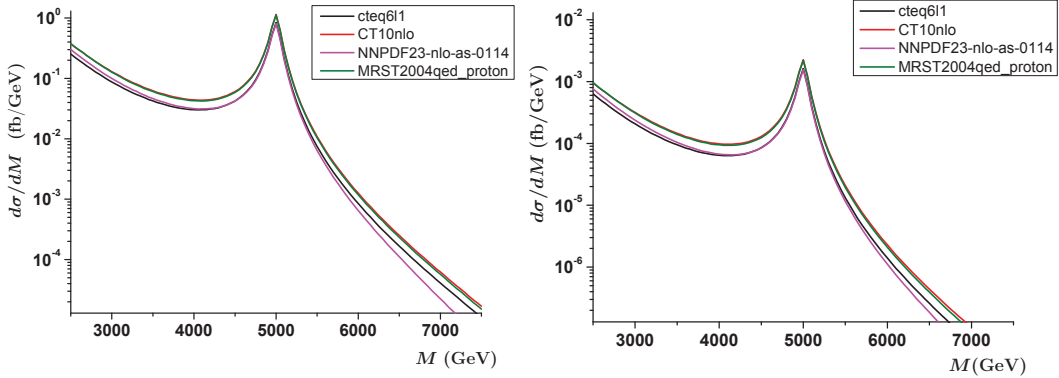
We now turn to the experimental predictions of TeV scale strings. Their main implications in particle accelerators are of four types, in correspondence with the four different sectors that are generally present:

1. New compactified parallel dimensions; In this case  $RM_s \gtrsim 1$ , and the associated compactification scale  $R_\parallel^{-1}$  would be the first scale of new physics that should be found increasing the beam energy [3, 7]. The main consequence is the existence of KK excitations for all SM particles that propagate along the extra parallel dimensions. These can be produced on-shell at LHC as new resonances [8] (see Fig. 3).
2. New extra large transverse dimensions and low scale quantum gravity,. The main experimental signal is gravitational radiation in the bulk from any physical process on the world-brane [9].

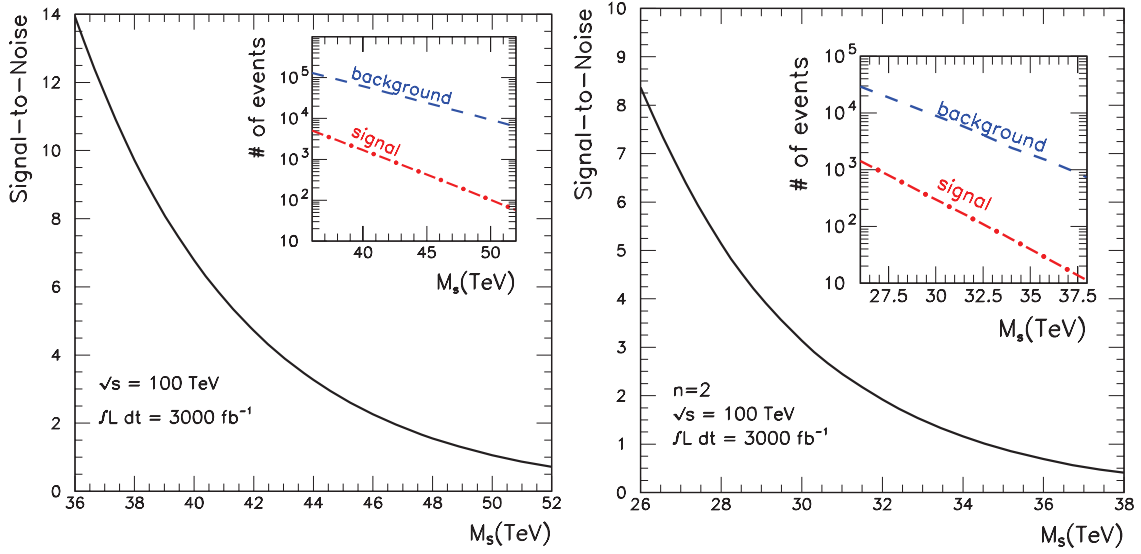


**Figure 3:** Production of the first KK modes of the photon and of the Z boson at LHC, decaying to electron-positron pairs. The number of expected events is plotted as a function of the energy of the pair in GeV.

3. Genuine string and quantum gravity effects. Direct production of string resonances in hadron colliders leads generically to a universal deviation from Standard Model in jet distribution [10]. In particular, the first Regge excitation of the gluon has spin 2 and a width an order of magnitude lower than the string scale, leading to a characteristic peak in dijet production; similarly, the first excitations of quarks have spin 3/2. The dijet (left) and  $\gamma$  + jet (right) cross-sections are shown in Fig. 4 for LHC energies, while Fig 5 shows the Signal-to-Noise ratio of the lowest massive Regge excitations for a 100 TeV future hadron collider [11].



**Figure 4:** Production of the first Regge excitations at LHC in the dijet (left) and  $\gamma$  + jet (right) channels, for  $M_s = 5$  TeV. The cross-section is plotted as a function of the invariant mass  $M$ .



**Figure 5:** Dijet signal-to-noise ratio of the lowest  $n = 1$  (left) and  $n = 2$  (right) Regge excitations for a future 100 TeV hadron collider.

4. Extra  $U(1)$ 's arising generically in D-brane models as part of unitary gauge group factors. They obtain in general masses due to four- or higher-dimensional anomalies, via the so-called Green-Schwarz anomaly cancellation mechanism involving axionic fields from the closed string sector. The resulting masses are therefore suppressed by a loop factor compared to the string scale. From the low energy point of view, they gauge global symmetries of the Standard Model, such as the baryon and lepton number. An important property of the anomaly cancellation mechanism is that the anomalous  $U(1)$  gauge bosons acquire masses leaving behind the corresponding global symmetries unbroken in perturbation theory. Thus, this is a way to guarantee proton stability (from unbroken baryon number) and avoid large Majorana neutrino masses (from unbroken lepton number) due to dimension-5 operators involving two higgses and two leptons that are suppressed only by the TeV string scale. Such extra  $U(1)$ s have interesting properties and distinct experimental signatures [12, 13, 14].
5. Concerning possible micro-black hole production, note that a string size black hole has a horizon radius  $r_H \sim 1$  in string units, while the Newton's constant behaves as  $G_N \sim g_s^2$ . It follows that the mass of a  $d$ -dimensional black hole is [15]:  $M_{\text{BH}} \sim r_H^{d/2-1}/G_N \simeq 1/g_s^2$ . Using the value of the SM gauge couplings  $g_s \simeq g^2 \sim 0.1$ , one finds that the energy threshold  $M_{\text{BH}}$  of micro-black hole production is about four orders of magnitude higher than the string scale, implying that one would produce  $10^4$  string states before reaching  $M_{\text{BH}}$ .

On the other hand, there exist interesting implications in non accelerator table-top experiments due to the exchange of gravitons or other possible states living in the bulk.

### 3. Large number of species

Here, we point out that low scale gravity with large extra dimensions is actually a particular

case of a more general framework, where the UV cutoff is lower than the Planck scale due to the existence of a large number of particle species coupled to gravity [16]. Indeed, it was shown that the effective UV cutoff  $M_{UV}$  is given by

$$M_{UV}^2 = M_P^2/N, \quad (3.1)$$

where the counting of independent species  $N$  takes into account all particles which are not broad resonances, having a width less than their mass. The derivation is based on black hole evaporation but here we present a shorter argument using quantum information storage [17]. Consider a pixel of size  $L$  containing  $N$  species storing information. The energy required to localize  $N$  wave functions is then given by  $N/L$ , associated to a Schwarzschild radius  $R_s = N/LM_P^2$ . The latter must be less than the pixel size in order to avoid the collapse of such a system to a black hole,  $R_s \leq L$ , implying a minimum size  $L \geq L_{min}$  with  $L_{min} = \sqrt{N}/M_P$  associated precisely to the effective UV cutoff  $M_{UV} = L_{min}$  given in eq. (3.1). Imposing  $M_{UV} \simeq 1$  TeV, one should then have  $N \sim 10^{32}$  particle species below about the TeV scale!

In the string theory context, there are two ways of realizing such a large number of particle species by lowering the string scale at a TeV:

1. In large volume compactifications with the SM localized on D-brane stacks, as described in the previous section. The particle species are then the Kaluza-Klein (KK) excitations of the graviton (and other possible bulk modes) associated to the large extra dimensions, given by  $N = R_{\perp}^n l_s^n$ , up to energies of order  $M_{UV} \simeq M_s$ .
2. By introducing an infinitesimal string coupling  $g_s \simeq 10^{-16}$  with the SM localized on Neveu-Schwarz NS5-branes in the framework of little strings [18]. In this case, the particle species are the effective number of string modes that contribute to the black hole bound [19]:  $N = 1/g_s^2$  and gravity does not become strong at  $M_s \sim \mathcal{O}(\text{TeV})$ .

Note that both TeV string realizations above are compatible with the general expression (2.1), but in the second case there is no relation between the string and gauge couplings.

#### 4. Standard Model on D-branes

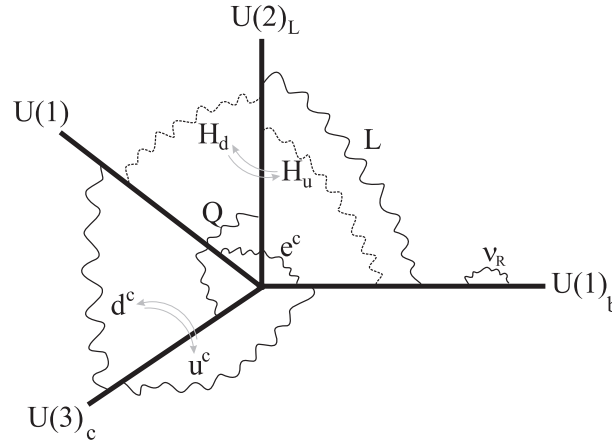
The gauge group closest to the Standard Model one can easily obtain with D-branes is  $U(3) \times U(2) \times U(1)$ . The first factor arises from three coincident ‘‘color’’ D-branes. An open string with one end on them is a triplet under  $SU(3)$  and carries the same  $U(1)$  charge for all three components. Thus, the  $U(1)$  factor of  $U(3)$  has to be identified with *gauged* baryon number. Similarly,  $U(2)$  arises from two coincident ‘‘weak’’ D-branes and the corresponding abelian factor is identified with *gauged* weak-doublet number. Finally, an extra  $U(1)$  D-brane is necessary in order to accommodate the Standard Model without breaking the baryon number [12]. In principle this  $U(1)$  brane can be chosen to be independent of the other two collections with its own gauge coupling. To improve the predictability of the model, we choose to put it on top of either the color or the weak D-branes [13]. In either case, the model has two independent gauge couplings  $g_3$  and  $g_2$  corresponding, respectively, to the gauge groups  $U(3)$  and  $U(2)$ . The  $U(1)$  gauge coupling  $g_1$  is equal to either  $g_3$  or  $g_2$ .

Let us denote by  $Q_3$ ,  $Q_2$  and  $Q_1$  the three  $U(1)$  charges of  $U(3) \times U(2) \times U(1)$ , in a self explanatory notation. Under  $SU(3) \times SU(2) \times U(1)_3 \times U(1)_2 \times U(1)_1$ , the members of a family of quarks and leptons have the following quantum numbers:

$$\begin{aligned}
 Q & (\mathbf{3}, \mathbf{2}; 1, w, 0)_{1/6} \\
 u^c & (\bar{\mathbf{3}}, \mathbf{1}; -1, 0, x)_{-2/3} \\
 d^c & (\bar{\mathbf{3}}, \mathbf{1}; -1, 0, y)_{1/3} \\
 L & (\mathbf{1}, \mathbf{2}; 0, 1, z)_{-1/2} \\
 l^c & (\mathbf{1}, \mathbf{1}; 0, 0, 1)_1
 \end{aligned} \tag{4.1}$$

The values of the  $U(1)$  charges  $x, y, z, w$  will be fixed below so that they lead to the right hypercharges, shown for completeness as subscripts.

It turns out that there are two possible ways of embedding the Standard Model particle spectrum on these stacks of branes [12], which are shown pictorially in Fig. 6. The quark doublet  $Q$



**Figure 6:** A minimal Standard Model embedding on D-branes.

corresponds necessarily to a massless excitation of an open string with its two ends on the two different collections of branes (color and weak). As seen from the figure, a fourth brane stack is needed for a complete embedding, which is chosen to be a  $U(1)_b$  extended in the bulk. This is welcome since one can accommodate right handed neutrinos as open string states on the bulk with sufficiently small Yukawa couplings suppressed by the large volume of the bulk [20]. The two models are obtained by an exchange of the up and down antiquarks,  $u^c$  and  $d^c$ , which correspond to open strings with one end on the color branes and the other either on the  $U(1)$  brane, or on the  $U(1)_b$  in the bulk. The lepton doublet  $L$  arises from an open string stretched between the weak branes and  $U(1)_b$ , while the antilepton  $l^c$  corresponds to a string with one end on the  $U(1)$  brane and the other in the bulk. For completeness, we also show the two possible Higgs states  $H_u$  and  $H_d$  that are both necessary in order to give tree-level masses to all quarks and leptons of the heaviest generation.



#### 4.1 Hypercharge embedding and the weak angle

The weak hypercharge  $Y$  is a linear combination of the three  $U(1)$ 's:

$$Y = Q_1 + \frac{1}{2}Q_2 + c_3Q_3 \quad ; \quad c_3 = -1/3 \text{ or } 2/3, \quad (4.2)$$

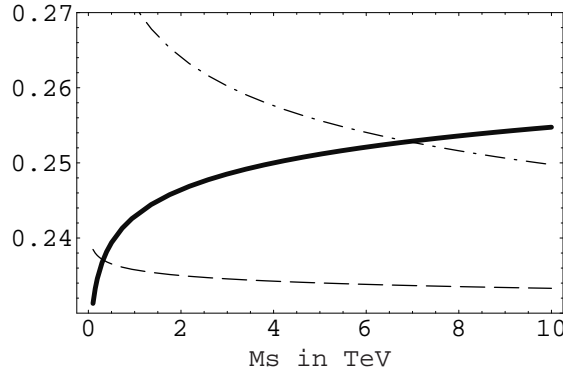
where  $Q_N$  denotes the  $U(1)$  generator of  $U(N)$  normalized so that the fundamental representation of  $SU(N)$  has unit charge. The corresponding  $U(1)$  charges appearing in eq. (4.1) are  $x = -1$  or  $0$ ,  $y = 0$  or  $1$ ,  $z = -1$ , and  $w = 1$  or  $-1$ , for  $c_3 = -1/3$  or  $2/3$ , respectively. The hypercharge coupling  $g_Y$  is given by <sup>1</sup>:

$$\frac{1}{g_Y^2} = \frac{2}{g_1^2} + \frac{4c_2^2}{g_2^2} + \frac{6c_3^2}{g_3^2}. \quad (4.3)$$

It follows that the weak angle  $\sin^2 \theta_W$ , is given by:

$$\sin^2 \theta_W \equiv \frac{g_Y^2}{g_2^2 + g_Y^2} = \frac{1}{2 + 2g_2^2/g_1^2 + 6c_3^2g_2^2/g_3^2}, \quad (4.4)$$

where  $g_N$  is the gauge coupling of  $SU(N)$  and  $g_1 = g_2$  or  $g_1 = g_3$  at the string scale. In order to compare the theoretical predictions with the experimental value of  $\sin^2 \theta_W$  at  $M_s$ , we plot in Fig. 7 the corresponding curves as functions of  $M_s$ . The solid line is the experimental curve. The



**Figure 7:** The experimental value of  $\sin^2 \theta_W$  (thick curve), and the theoretical predictions.

dashed line is the plot of the function (4.4) for  $g_1 = g_2$  with  $c_3 = -1/3$  while the dotted-dashed line corresponds to  $g_1 = g_3$  with  $c_3 = 2/3$ . The other two possibilities are not shown because they lead to a value of  $M_s$  which is too high to protect the hierarchy. Thus, the second case, where the  $U(1)$  brane is on top of the color branes, is compatible with low energy data for  $M_s \sim 6 - 8$  TeV and  $g_s \simeq 0.9$ .

From Eq. (4.4) and Fig. 7, we find the ratio of the  $SU(2)$  and  $SU(3)$  gauge couplings at the string scale to be  $\alpha_2/\alpha_3 \sim 0.4$ . This ratio can be arranged by an appropriate choice of the relevant moduli. For instance, one may choose the color and  $U(1)$  branes to be D3 branes while the weak

<sup>1</sup>The gauge couplings  $g_{2,3}$  are determined at the tree-level by the string coupling and other moduli, like radii of longitudinal dimensions. In higher orders, they also receive string threshold corrections.

branes to be D7 branes. Then, the ratio of couplings above can be explained by choosing the volume of the four compact dimensions of the seven branes to be  $V_4 = 2.5$  in string units. This being larger than one is consistent with the picture above. Moreover it predicts an interesting spectrum of KK states for the Standard model, different from the naive choices that have appeared hitherto: the only Standard Model particles that have KK descendants are the W bosons as well as the hypercharge gauge boson. However, since the hypercharge is a linear combination of the three  $U(1)$ 's, the massive  $U(1)$  KK gauge bosons do not couple to the hypercharge but to the weak doublet number.

#### 4.2 The fate of $U(1)$ 's, proton stability and neutrino masses

It is easy to see that the remaining three  $U(1)$  combinations orthogonal to  $Y$  are anomalous. In particular there are mixed anomalies with the  $SU(2)$  and  $SU(3)$  gauge groups of the Standard Model. These anomalies are cancelled by three axions coming from the closed string RR (Ramond) sector, via the standard Green-Schwarz mechanism [21]. The mixed anomalies with the non-anomalous hypercharge are also cancelled by dimension five Chern-Simmons type of interactions [12]. An important property of the above Green-Schwarz anomaly cancellation mechanism is that the anomalous  $U(1)$  gauge bosons acquire masses leaving behind the corresponding global symmetries. This is in contrast to what would had happened in the case of an ordinary Higgs mechanism. These global symmetries remain exact to all orders in type I string perturbation theory around the orientifold vacuum. This follows from the topological nature of Chan-Paton charges in all string amplitudes. On the other hand, one expects non-perturbative violation of global symmetries and consequently exponentially small in the string coupling, as long as the vacuum stays at the orientifold point. Thus, all  $U(1)$  charges are conserved and since  $Q_3$  is the baryon number, proton stability is guaranteed.

Another linear combination of the  $U(1)$ 's is the lepton number. Lepton number conservation is important for the extra dimensional neutrino mass suppression mechanism described above, that can be destabilized by the presence of a large Majorana neutrino mass term. Such a term can be generated by the lepton-number violating dimension five effective operator  $LLHH$  that leads, in the case of TeV string scale models, to a Majorana mass of the order of a few GeV. Even if we manage to eliminate this operator in some particular model, higher order operators would also give unacceptably large contributions, as we focus on models in which the ratio between the Higgs vacuum expectation value and the string scale is just of order  $\mathcal{O}(1/10)$ . The best way to protect tiny neutrino masses from such contributions is to impose lepton number conservation.

A bulk neutrino propagating in  $4+n$  dimensions can be decomposed in a series of 4d KK excitations denoted collectively by  $\{m\}$ :

$$S_{kin} = R_{\perp}^n \int d^4x \sum_{\{m\}} \left\{ \bar{\nu}_{Rm} \not{\partial} \nu_{Rm} + \bar{\nu}_{Rm}^c \not{\partial} \nu_{Rm}^c + \frac{m}{R_{\perp}} \nu_{Rm} \nu_{Rm}^c + c.c. \right\}, \quad (4.5)$$

where  $\nu_R$  and  $\nu_R^c$  are the two Weyl components of the Dirac spinor and for simplicity we considered a common compactification radius  $R_{\perp}$ . On the other hand, there is a localized interaction of  $\nu_R$  with the Higgs field and the lepton doublet, which leads to mass terms between the left-handed neutrino and the KK states  $\nu_{Rm}$ , upon the Higgs VEV  $v$ :

$$S_{int} = g_s \int d^4x H(x) L(x) \nu_R(x, y=0) \rightarrow \frac{g_s v}{R_{\perp}^{n/2}} \sum_m \nu_L \nu_{Rm}, \quad (4.6)$$

in strings units. Since the mass mixing  $g_s v/R_\perp^{n/2}$  is much smaller than the KK mass  $1/R_\perp$ , it can be neglected for all the excitations except for the zero-mode  $\nu_{R0}$ , which gets a Dirac mass with the left-handed neutrino

$$m_\nu \simeq \frac{g_s v}{R_\perp^{n/2}} \simeq v \frac{M_s}{M_p} \simeq 10^{-3} - 10^{-2} \text{ eV}, \quad (4.7)$$

for  $M_s \simeq 1 - 10$  TeV, where the relation (2.1) was used. In principle, with one bulk neutrino, one could try to explain both solar and atmospheric neutrino oscillations using also its first KK excitation. However, the later behaves like a sterile neutrino which is now excluded experimentally. Therefore, one has to introduce three bulk species (at least two)  $\nu_R^i$  in order to explain neutrino oscillations in a ‘traditional way’, using their zero-modes  $\nu_{R0}^i$  [22]. The main difference with the usual seesaw mechanism is the Dirac nature of neutrino masses, which remains an open possibility to be tested experimentally.

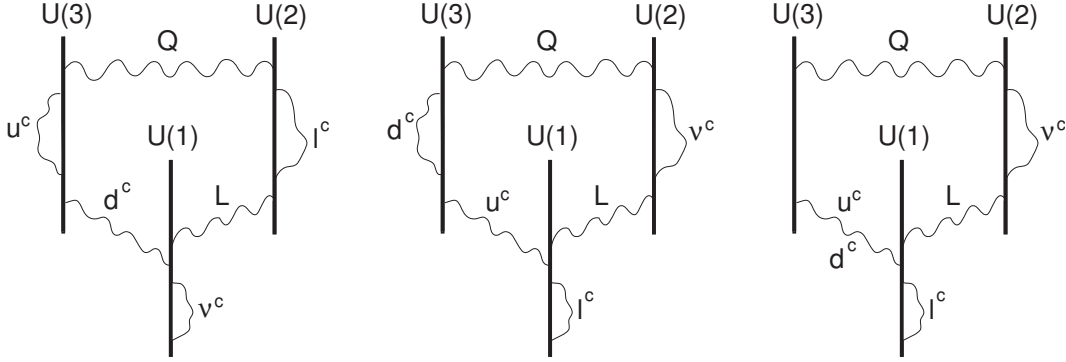
## 5. Minimal Standard Model embedding

In this section, we perform a general study of SM embedding in three brane stacks with gauge group  $U(3) \times U(2) \times U(1)$  [12, 23], and present an explicit example having realistic particle content and satisfying gauge coupling unification [24]. We consider in general non oriented strings because of the presence of the orientifold plane that gives rise to mirror branes. An open string stretched between a brane stack  $U(N)$  and its mirror transforms in the symmetric or antisymmetric representation, while the multiplicity of chiral fermions is given by their intersection number.

The quark and lepton doublets ( $Q$  and  $L$ ) correspond to open strings stretched between the weak and the color or  $U(1)$  branes, respectively. On the other hand, the  $u^c$  and  $d^c$  antiquarks can come from strings that are either stretched between the color and  $U(1)$  branes, or that have both ends on the color branes (stretched between the brane stack and its orientifold image) and transform in the antisymmetric representation of  $U(3)$  (which is an anti-triplet). There are therefore three possible models, depending on whether it is the  $u^c$  (model A), or the  $d^c$  (model B), or none of them (model C), the state coming from the antisymmetric representation of color branes. It follows that the antilepton  $l^c$  comes in a similar way from open strings with both ends either on the weak brane stack and transforming in the antisymmetric representation of  $U(2)$  which is an  $SU(2)$  singlet (in model A), or on the abelian brane and transforming in the ‘‘symmetric’’ representation of  $U(1)$  (in models B and C). The three models are presented pictorially in Fig. 5

Thus, the members of a family of quarks and leptons have the following quantum numbers:

	Model A	Model B	Model C	
$Q$	$(\mathbf{3}, \mathbf{2}; 1, 1, 0)_{1/6}$	$(\mathbf{3}, \mathbf{2}; 1, \varepsilon_Q, 0)_{1/6}$	$(\mathbf{3}, \mathbf{2}; 1, \varepsilon_Q, 0)_{1/6}$	
$u^c$	$(\bar{\mathbf{3}}, \mathbf{1}; 2, 0, 0)_{-2/3}$	$(\bar{\mathbf{3}}, \mathbf{1}; -1, 0, 1)_{-2/3}$	$(\bar{\mathbf{3}}, \mathbf{1}; -1, 0, 1)_{-2/3}$	
$d^c$	$(\bar{\mathbf{3}}, \mathbf{1}; -1, 0, \varepsilon_d)_{1/3}$	$(\bar{\mathbf{3}}, \mathbf{1}; 2, 0, 0)_{1/3}$	$(\bar{\mathbf{3}}, \mathbf{1}; -1, 0, -1)_{1/3}$	(5.1)
$L$	$(\mathbf{1}, \mathbf{2}; 0, -1, \varepsilon_L)_{-1/2}$	$(\mathbf{1}, \mathbf{2}; 0, \varepsilon_L, 1)_{-1/2}$	$(\mathbf{1}, \mathbf{2}; 0, \varepsilon_L, 1)_{-1/2}$	
$l^c$	$(\mathbf{1}, \mathbf{1}; 0, 2, 0)_1$	$(\mathbf{1}, \mathbf{1}; 0, 0, -2)_1$	$(\mathbf{1}, \mathbf{1}; 0, 0, -2)_1$	
$\nu^c$	$(\mathbf{1}, \mathbf{1}; 0, 0, 2\varepsilon_\nu)_0$	$(\mathbf{1}, \mathbf{1}; 0, 2\varepsilon_\nu, 0)_0$	$(\mathbf{1}, \mathbf{1}; 0, 2\varepsilon_\nu, 0)_0$	



**Figure 8:** Pictorial representation of models A, B and C

where the last three digits after the semi-column in the brackets are the charges under the three abelian factors  $U(1)_3 \times U(1)_2 \times U(1)$ , that we will call  $Q_3$ ,  $Q_2$  and  $Q_1$  in the following, while the subscripts denote the corresponding hypercharges. The various sign ambiguities  $\varepsilon_i = \pm 1$  are due to the fact that the corresponding abelian factor does not participate in the hypercharge combination (see below). In the last lines, we also give the quantum numbers of a possible right-handed neutrino in each of the three models. These are in fact all possible ways of embedding the SM spectrum in three sets of branes.

The hypercharge combination is:

$$\begin{aligned} \text{Model A} & : Y = -\frac{1}{3}Q_3 + \frac{1}{2}Q_2 \\ \text{Model B,C} & : Y = \frac{1}{6}Q_3 - \frac{1}{2}Q_1 \end{aligned} \quad (5.2)$$

leading to the following expressions for the weak angle:

$$\begin{aligned} \text{Model A} : \sin^2 \theta_W &= \frac{1}{2 + 2\alpha_2/3\alpha_3} = \frac{3}{8} \Big|_{\alpha_2=\alpha_3} \\ \text{Model B,C} : \sin^2 \theta_W &= \frac{1}{1 + \alpha_2/2\alpha_1 + \alpha_2/6\alpha_3} \\ &= \frac{6}{7 + 3\alpha_2/\alpha_1} \Big|_{\alpha_2=\alpha_3} \end{aligned} \quad (5.3)$$

In the second part of the above equalities, we used the unification relation  $\alpha_2 = \alpha_3$ , that can be imposed if for instance  $U(3)$  and  $U(2)$  branes are coincident, leading to a  $U(5)$  unified group. Alternatively, this condition can be generally imposed under mild assumptions [24]. It follows that model A admits natural gauge coupling unification of strong and weak interactions, and predicts the correct value for  $\sin^2 \theta_W = 3/8$  at the unification scale  $M_{\text{GUT}}$ . On the other hand, model B corresponds to the flipped  $SU(5)$  where the role of  $u^c$  and  $d^c$  is interchanged together with  $l^c$  and  $\nu^c$  between the  $\mathbf{10}$  and  $\bar{\mathbf{5}}$  representations [25].

Besides the hypercharge combination, there are two additional  $U(1)$ 's. It is easy to check that one of the two can be identified with  $B - L$ . For instance, in model A choosing the signs

$\varepsilon_d = \varepsilon_L = -\varepsilon_\nu = -\varepsilon_H = \varepsilon_{H'}$ , it is given by:

$$B - L = -\frac{1}{6}Q_3 + \frac{1}{2}Q_2 - \frac{\varepsilon_d}{2}Q_1. \quad (5.4)$$

Finally, the above spectrum can be easily implemented with a Higgs sector, since the Higgs field  $H$  has the same quantum numbers as the lepton doublet or its complex conjugate.

## 6. Effective Planck mass and the inflation scale

Here, we work out the consequences of the change of strength of gravity for inferring various quantities during inflation [26], which we take to be driven by a single field for economy of discussion and because the data doesn't compel us to consider otherwise [27]. As is to be expected, all dimensionless observables such as the amplitude and spectral properties of the perturbations are unaffected by the changing strength of gravity at inflationary energies. However, when one tries to *infer* an absolute energy scale for inflation, one finds that it is undetermined commensurate with (3.1) up to the unknown spectrum of universally coupled species between laboratory scales and the inflationary scale, the details of which we elaborate upon in the following.

According to the inflationary paradigm, the primordial perturbations observed in the CMB were created at horizon crossing during the quasi de Sitter (dS) phase of early accelerated expansion sourced by the inflaton field. Therefore all quantities that enter calculations of primordial correlation functions (which we subsequently relate to observables in the CMB) refer to quantities at the scale at which inflation occurred. We denote all quantities measured at the scale of inflation with a starred subscript. The dominant contribution to the temperature anisotropies comes from adiabatic perturbations<sup>2</sup> sourced by the comoving curvature perturbation  $\mathcal{R}$ , defined as the conformal factor of the 3-metric  $h_{ij}$  in comoving gauge:

$$h_{ij}(t, x) = a^2(t)e^{2\mathcal{R}(t, x)}\hat{h}_{ij}; \quad \hat{h}_{ij} := \exp[\gamma_{ij}] \quad (6.1)$$

with  $\partial_i \gamma_{ij} = \gamma_{ii} = 0$  defining transverse traceless graviton perturbations. The temperature anisotropies are characterized by the dimensionless power spectrum for  $\mathcal{R}$ , whose amplitude is given by

$$\mathcal{P}_{\mathcal{R}} := \frac{H_*^2}{8\pi^2 M_*^2 \varepsilon_*} = \mathcal{A} \times 10^{-10}, \quad (6.2)$$

where  $\varepsilon_* := -\dot{H}_*/H_*^2$ ,  $H_*$  being the Hubble factor during inflation. Given that  $\mathcal{R}$  is conserved on super-horizon scales (in the absence of entropy perturbations), this immediately relates to the amplitude of the late time CMB anisotropies, which fixes  $\mathcal{A} \sim 22.15$  [27]. The tensor anisotropies are characterized by the tensor power spectrum

$$\mathcal{P}_\gamma := 2 \frac{H_*^2}{\pi^2 M_*^2}, \quad (6.3)$$

---

<sup>2</sup>In what follows, we assume that all of the extra species have sufficiently suppressed couplings to the inflaton during inflation (e.g. either through derivative couplings or as Planck suppressed interactions) so that isocurvature perturbations are not significantly generated. This is trivially true for hidden sector fields.

Taking the ratio of the above with (6.2), we find the tensor to scalar ratio

$$r_* := \frac{\mathcal{P}_\gamma}{\mathcal{P}_\mathcal{R}} = 16\epsilon_*. \quad (6.4)$$

Therefore any determination of  $r_*$ , either through direct measurements of the stochastic background of primordial gravitational waves or through their secondary effects on the polarization of the CMB [28, 29, 30] allows us in principle to fix the scale of inflation:

$$H_* = M_* \left( \frac{\pi^2 \mathcal{A} r_*}{2 \cdot 10^{10}} \right)^{1/2} := \Upsilon = 1.05 \sqrt{r_*} \times 10^{-4}. \quad (6.5)$$

We see that any measurements of  $r_*$  determines the scale of inflation *up to our ignorance of the effective strength of gravity at the scale  $H_*$* , given by  $M_* \sim \frac{M_p}{\sqrt{N}}$ , where  $N$  is the effective number of all universally coupled species up to the scale  $H_*$ — whether they exist in the visible sector or in any hidden sector. Note that as one lowers the scale of strong gravity, the maximum reheating temperature  $T_i$  is necessarily lowered as well, since it cannot be higher than the inflation scale. Conservatively,  $T_i$  cannot be too far below the TeV scale without spoiling the standard scenarios of big bang cosmology— in particular, mechanisms for Leptogenesis and Baryogenesis which can occur no lower than the electroweak scale [31]. We note as a consistency check on the above considerations, that although additional species increase the strength of gravity, the ratio  $H_*^2/M_*^2$  is independent of  $N$  and is fixed by observable quantities. Therefore the effects of strong gravity are evidently negligible during inflation even if  $M_*$  is much smaller than the macroscopic strength of gravity  $M_{\text{pl}}$ . Hence inflationary dynamics, in particular the dynamics of adiabatic fluctuations remain weakly coupled independent of  $N$  and the usual computation of adiabatic correlators can be implemented [32].

In the case of extra species as KK graviton modes, the fundamental higher-dimensional gravity scale (3.1) with  $N \simeq R_\perp^n E_*^n$  at a given energy scale  $E_*$ , for  $E_* = M_{UV}$  leads to the usual relation between the 4d and  $(4+n)$ d Planck scales

$$M_p^2 = M_{UV}^{2+n} R_\perp^n. \quad (6.6)$$

On the other hand, during inflation  $N$  counts all KK states with mass less than the Hubble scale  $H_*$ :

$$N = (H_* R_\perp)^n, \quad (6.7)$$

and the effective gravity scale becomes

$$M_* = M_p / \sqrt{N} = M_{UV} (M_{UV}/H)^{n/2}, \quad (6.8)$$

where we used the relations (6.6) and (6.8). Equation (6.5) then yields:

$$H_* = M_* \Upsilon = M_{UV} (M_{UV}/H)^{n/2} \Upsilon \Rightarrow M_{UV} \Upsilon^{2/(n+2)}, \quad (6.9)$$

where we used eq. (6.8). It follows that  $H_*$  is one to three orders of magnitude below the fundamental gravity scale  $M_{UV}$  for the range  $0.001 \lesssim r_* \lesssim 0.1$ . The ratio  $H_*/M_*$  is of course fixed by (6.5). The inflation scale  $H_*$  can then be as low as the weak scale in low scale gravity models with large extra dimensions, consistently with observations.

## 7. Conclusions

In this note, I gave a short overview of large extra dimensions and low scale gravity in the context of string theory that provides a consistent quantum framework of unification of all fundamental forces of Nature, including gravity. String theory introduces a new fundamental energy scale associated with the string tension, or equivalently with the inverse string size. Its value can be high, near the four-dimensional Planck mass, compatible with traditional (supersymmetric) grand unification, or lower, up to the TeV scale providing an answer alternative to supersymmetry for solving the so-called hierarchy problem. The appropriate framework for such a realization is the (weakly coupled) type I theory of closed and open strings with D-branes. I have shown how the Standard Model can be embedded in such a framework.

## References

- [1] For a review, see e.g. K. R. Dienes, *Phys. Rept.* **287** (1997) 447 [arXiv:hep-th/9602045]; and references therein.
- [2] C. Angelantonj and A. Sagnotti, *Phys. Rept.* **371** (2002) 1 [Erratum-ibid. **376** (2003) 339] [arXiv:hep-th/0204089].
- [3] I. Antoniadis, *Phys. Lett. B* **246** (1990) 377.
- [4] D. J. Kapner, T. S. Cook, E. G. Adelberger, J. H. Gundlach, B. R. Heckel, C. D. Hoyle and H. E. Swanson, *Phys. Rev. Lett.* **98** (2007) 021101.
- [5] N. Arkani-Hamed, S. Dimopoulos and G. R. Dvali, *Phys. Lett. B* **429** (1998) 263 [arXiv:hep-ph/9803315]; I. Antoniadis, N. Arkani-Hamed, S. Dimopoulos and G. R. Dvali, *Phys. Lett. B* **436** (1998) 257 [arXiv:hep-ph/9804398].
- [6] J. C. Long and J. C. Price, *Comptes Rendus Physique* **4** (2003) 337; R. S. Decca, D. Lopez, H. B. Chan, E. Fischbach, D. E. Krause and C. R. Jamell, *Phys. Rev. Lett.* **94** (2005) 240401; R. S. Decca et al., arXiv:0706.3283 [hep-ph]; S. J. Smullin, A. A. Geraci, D. M. Weld, J. Chiaverini, S. Holmes and A. Kapitulnik, arXiv:hep-ph/0508204; H. Abele, S. Haeßler and A. Westphal, in 271th WE-Heraeus-Seminar, Bad Honnef (2002).
- [7] I. Antoniadis and K. Benakli, *Phys. Lett. B* **326** (1994) 69.
- [8] I. Antoniadis, K. Benakli and M. Quirós, *Phys. Lett. B* **331** (1994) 313 and *Phys. Lett. B* **460** (1999) 176; P. Nath, Y. Yamada and M. Yamaguchi, *Phys. Lett. B* **466** (1999) 100 T. G. Rizzo and J. D. Wells, *Phys. Rev. D* **61** (2000) 016007; T. G. Rizzo, *Phys. Rev. D* **61** (2000) 055005; A. De Rujula, A. Donini, M. B. Gavela and S. Rigolin, *Phys. Lett. B* **482** (2000) 195.
- [9] G.F. Giudice, R. Rattazzi and J.D. Wells, *Nucl. Phys. B* **544** (1999) 3; E.A. Mirabelli, M. Perelstein and M.E. Peskin, *Phys. Rev. Lett.* **82** (1999) 2236; T. Han, J.D. Lykken and R. Zhang, *Phys. Rev. D* **59** (1999) 105006; K. Cheung, W.-Y. Keung, *Phys. Rev. D* **60** (1999) 112003; C. Balázs et al., *Phys. Rev. Lett.* **83** (1999) 2112; J.L. Hewett, *Phys. Rev. Lett.* **82** (1999) 4765.
- [10] L.A. Anchordoqui, H. Goldberg, D. Lust, S. Nawata, S. Stieberger and T.R. Taylor, *Phys. Rev. Lett.* **101** (2008) 241803 [arXiv:0808.0497 [hep-ph]].
- [11] L. A. Anchordoqui, I. Antoniadis, D. C. Dai, W. Z. Feng, H. Goldberg, X. Huang, D. Lust and D. Stojkovic et al., *Phys. Rev. D* **90** (2014) 6, 066013 [arXiv:1407.8120 [hep-ph]].



- [12] I. Antoniadis, E. Kiritsis and T. N. Tomaras, *Phys. Lett. B* **486**, 186 (2000) [arXiv:hep-ph/0004214]; I. Antoniadis, E. Kiritsis, J. Rizos and T. N. Tomaras, *Nucl. Phys. B* **660**, 81 (2003) [arXiv:hep-th/0210263].
- [13] G. Shiu and S.-H. H. Tye, *Phys. Rev. D* **58** (1998) 106007; Z. Kakushadze and S.-H. H. Tye, *Nucl. Phys. B* **548** (1999) 180; L. E. Ibáñez, C. Muñoz and S. Rigolin, *Nucl. Phys. B* **553** (1999) 43.
- [14] I. Antoniadis, E. Kiritsis and J. Rizos, *Nucl. Phys. B* **637**, 92 (2002) [arXiv:hep-th/0204153]; L. A. Anchordoqui, I. Antoniadis, H. Goldberg, X. Huang, D. Lust and T. R. Taylor, *Phys. Rev. D* **85** (2012) 086003 [arXiv:1107.4309 [hep-ph]].
- [15] G.T. Horowitz and J. Polchinski, *Phys. Rev. D* **55** (1997) 6189.
- [16] G. Dvali, arXiv:0706.2050 [hep-th]; *Int. J. Mod. Phys. A* **25** (2010) 602 [arXiv:0806.3801 [hep-th]]; G. Dvali and M. Redi, *Phys. Rev. D* **77** (2008) 045027 [arXiv:0710.4344 [hep-th]]; R. Brustein, G. Dvali and G. Veneziano, *JHEP* **0910** (2009) 085 [arXiv:0907.5516 [hep-th]].
- [17] G. Dvali and C. Gomez, *Phys. Lett. B* **674** (2009) 303.
- [18] I. Antoniadis and B. Pioline, *Nucl. Phys. B* **550** (1999) 41; I. Antoniadis, S. Dimopoulos and A. Giveon, *JHEP* **0105** (2001) 055 [arXiv:hep-th/0103033]; I. Antoniadis, A. Arvanitaki, S. Dimopoulos and A. Giveon, arXiv:1102.4043.
- [19] G. Dvali and D. Lust, arXiv:0912.3167 [hep-th]; G. Dvali and C. Gomez, arXiv:1004.3744 [hep-th].
- [20] K. R. Dienes, E. Dudas and T. Gherghetta, *Nucl. Phys. B* **557** (1999) 25 [arXiv:hep-ph/9811428]; N. Arkani-Hamed, S. Dimopoulos, G. R. Dvali and J. March-Russell, *Phys. Rev. D* **65** (2002) 024032 [arXiv:hep-ph/9811448]; G. R. Dvali and A. Y. Smirnov, *Nucl. Phys. B* **563** (1999) 63.
- [21] A. Sagnotti, *Phys. Lett. B* **294** (1992) 196; L. E. Ibáñez, R. Rabadán and A. M. Uranga, *Nucl. Phys. B* **542** (1999) 112; E. Poppitz, *Nucl. Phys. B* **542** (1999) 31.
- [22] H. Davoudiasl, P. Langacker and M. Perelstein, *Phys. Rev. D* **65** (2002) 105015 [arXiv:hep-ph/0201128].
- [23] R. Blumenhagen, B. Kors, D. Lust and T. Ott, *Nucl. Phys. B* **616** (2001) 3 [arXiv:hep-th/0107138]; M. Cvetič, G. Shiu and A. M. Uranga, *Nucl. Phys. B* **615**, 3 (2001) [arXiv:hep-th/0107166]; I. Antoniadis and J. Rizos, 2003 unpublished work.
- [24] I. Antoniadis and S. Dimopoulos, *Nucl. Phys. B* **715**, 120 (2005) [arXiv:hep-th/0411032].
- [25] S. M. Barr, *Phys. Lett. B* **112** (1982) 219; J. P. Derendinger, J. E. Kim and D. V. Nanopoulos, *Phys. Lett. B* **139** (1984) 170; I. Antoniadis, J. R. Ellis, J. S. Hagelin and D. V. Nanopoulos, *Phys. Lett. B* **194** (1987) 231.
- [26] I. Antoniadis and S. P. Patil, *Eur. Phys. J. C* **75** (2015) 182 [arXiv:1410.8845 [hep-th]].
- [27] P. A. R. Ade *et al.* [Planck Collaboration], *Astron. Astrophys.* (2014) [arXiv:1303.5076 [astro-ph.CO]]; arXiv:1303.5082 [astro-ph.CO].
- [28] A. G. Polnarev, *Sov. Astron.* **29**, 607 (1985).
- [29] M. Kamionkowski, A. Kosowsky and A. Stebbins, *Phys. Rev. Lett.* **78**, 2058 (1997) [astro-ph/9609132].
- [30] U. Seljak and M. Zaldarriaga, *Phys. Rev. Lett.* **78**, 2054 (1997) [astro-ph/9609169].
- [31] M. Trodden, *Rev. Mod. Phys.* **71**, 1463 (1999) [hep-ph/9803479]; S. Davidson, E. Nardi and Y. Nir, *Phys. Rept.* **466**, 105 (2008) [arXiv:0802.2962 [hep-ph]].
- [32] C. Cheung, P. Creminelli, A. L. Fitzpatrick, J. Kaplan and L. Senatore, *JHEP* **0803**, 014 (2008) [arXiv:0709.0293 [hep-th]].