

CP asymmetries in D decays to two pseudoscalars

Ulrich Nierste*

*Institute for Theoretical Particle Physics (TTP)
Karlsruhe Institute of Technology (KIT)
76131 Karlsruhe, Germany
E-mail: ulrich.nierste@kit.edu*

Stefan Schacht

*Dipartimento di Fisica
Università di Torino & INFN
Sezione di Torino, 10125 Torino, Italy
E-mail: stefan.schacht@to.infn.it*

This talk addresses two topics related to CP asymmetries in D meson decays to two pseudoscalar mesons. First I discuss how new physics can be distinguished from the Standard Model through two sum rules relating three direct CP asymmetries each, using the sum rule correlating $D^0 \rightarrow K^+K^-$, $D^0 \rightarrow \pi^+\pi^-$, and $D^0 \rightarrow \pi^0\pi^0$ for illustration. The other sum rule involves $a_{CP}^{\text{dir}}(D^+ \rightarrow \bar{K}^0K^+)$, $a_{CP}^{\text{dir}}(D_s^+ \rightarrow K^0\pi^+)$, and $a_{CP}^{\text{dir}}(D_s^+ \rightarrow K^+\pi^0)$. The second topic is the direct CP asymmetry in the decay $D^0 \rightarrow K_S K_S$, which is expected to be large in the Standard Model for two reasons: Flavor-SU(3) symmetry suppresses the tree amplitude which enhances the crucial “penguin-to-tree” ratio and the “penguin” amplitude is dominated by the tree-level W boson exchange between c and u quarks. We find that $|a_{CP}^{\text{dir}}(D^0 \rightarrow K_S K_S)|$ can be as large as 1.1% in the Standard Model. We advocate $D^0 \rightarrow K_S K_S$ as a discovery channel for charm CP violation.

*38th International Conference on High Energy Physics
3-10 August 2016
Chicago, USA*

*Speaker.

1. Introduction

CP asymmetries in the charm system play a special role in the search for new physics, because they probe flavor-changing transitions among up-type quarks. At present, a prime effort of experimental charm physics is the discovery of CP violation in charm decays. Within the Standard Model (SM) charm CP asymmetries are small, because the relevant combination of elements of the Cabibbo-Kobayashi-Maskawa (CKM) matrix is of order 10^{-3} . Precise theoretical predictions are very difficult and vary by several orders of magnitude [1–15]. Since experimental sensitivities have increased to a level that measurements probe the range of SM predictions, we need new ideas to draw the demarcation line between SM and new physics more precisely. In this talk I discuss two-body weak decays of D^+, D^0, D_s^+ mesons into two pseudoscalar mesons $P, P' = \pi^0, \pi^\pm, K_{S,L}, K^\pm$. My two topics are

- (i) sum rules relating CP asymmetries in three different D decays and
- (ii) the CP asymmetry in the decay $D^0 \rightarrow K_S K_S$.

Topic (i) addresses a test of the Standard Model which will only work, if at least one of the involved CP asymmetries is measured non-zero. On the contrary, topic (ii) is about a discovery mode for charm CP violation for the case that the Kobayashi-Maskawa phase is the only source of CP violation.

Charm decay amplitudes are classified in terms of powers of the Wolfenstein parameter

$$\lambda \simeq |V_{us}| \simeq |V_{cd}| \simeq 0.22. \quad (1.1)$$

Amplitudes with $A \propto \begin{cases} \lambda^0 \\ \lambda^1 \\ \lambda^2 \end{cases}$ are called $\left\{ \begin{array}{l} \text{Cabibbo-favoured (CF)} \\ \text{singly Cabibbo-suppressed (SCS)} \\ \text{doubly Cabibbo-suppressed (DCS)} \end{array} \right\}$. In SCS amplitudes three CKM structures appear,

$$\lambda_d = V_{cd}^* V_{ud}, \quad \lambda_s = V_{cs}^* V_{us}, \quad \lambda_b = V_{cb}^* V_{ub},$$

and CKM unitarity $\lambda_d + \lambda_s + \lambda_b = 0$ is invoked to eliminate one combination of CKM elements. A common choice for the decomposition of an SCS decay amplitude is

$$\mathcal{A}^{\text{SCS}} \equiv \lambda_{sd} A_{sd} - \frac{\lambda_b}{2} A_b \quad (1.2)$$

with

$$\lambda_{sd} = \frac{\lambda_s - \lambda_d}{2} \quad \text{and} \quad -\frac{\lambda_b}{2} = \frac{\lambda_s + \lambda_d}{2}. \quad (1.3)$$

In view of $|\lambda_b|/|\lambda_{sd}| \sim 10^{-3}$ only A_{sd} is relevant for branching ratios. Within the SM a non-vanishing direct CP asymmetry involves the interference of $\lambda_b A_b$ with $\lambda_{sd} A_{sd}$. Neglecting quadratic (and higher) terms in λ_b/λ_{sd} the direct CP asymmetry reads

$$a_{CP}^{\text{dir}} = \text{Im} \frac{\lambda_b}{\lambda_{sd}} \text{Im} \frac{A_b}{A_{sd}} \quad (1.4)$$

Using $\mathcal{A}^{\text{SCS}} \simeq \lambda_{sd} A_{sd}$ and the standard CKM phase convention with (essentially) $\lambda_{sd} > 0$ Eq. (1.4) becomes

$$a_{CP}^{\text{dir}} = \frac{\text{Im} \lambda_b}{|\mathcal{A}^{\text{SCS}}|} \text{Im} \frac{A_b}{A_{sd}} |A_{sd}|. \quad (1.5)$$

Recalling that $|\mathcal{A}^{\text{SCS}}|$ is determined by the well-measured branching ratio of the considered decay we realize from Eq. (1.5) that two non-trivial inputs are needed to predict a_{CP}^{dir} : $|A_b|$ and the relative phase between A_b and A_{sd} . The latter is a CP-conserving (strong) phase; the CP-violating (weak) phase is $\arg(\lambda_b/\lambda_{sd})$.

It is not possible to calculate $|A_b|$ and $\arg(A_b/A_{sd})$ from first principles. The theoretical method of choice in charm physics is the approximate $\text{SU}(3)_F$ symmetry of QCD, which permits to correlate the amplitudes of different decays with each other. $\text{SU}(3)_F$ symmetry refers to unitary rotations among up, down, and strange fields and would be exact in the limit $m_u = m_d = m_s$ of equal light-quark masses. The parameter determining the size of $\text{SU}(3)_F$ breaking is $(m_s - m_d)/\Lambda_{\text{QCD}} = \mathcal{O}(30\%)$, where Λ_{QCD} is the fundamental scale of QCD. The actual accuracy of $\text{SU}(3)_F$ symmetry varies among different observables and it is desirable to include first-order (linear) $\text{SU}(3)_F$ breaking.

2. Sum rules of CP asymmetries

$\text{SU}(3)_F$ analyses can be done in two ways: First, one may express the physical decay amplitudes in terms of group-theoretical objects, the reduced amplitudes, which correspond to different representations of $\text{SU}(3)$. It is possible to include first-order $\text{SU}(3)_F$ breaking at the expense of having to deal with more reduced amplitudes (see e.g. [1, 7, 16]). Second, one can instead express the D decay amplitudes in terms of topological amplitudes, which are classified by the flavour flow [18–20]. Also this method allows for the inclusion of first-order $\text{SU}(3)_F$ breaking [21, 22]. The topological amplitudes are illustrated in Fig. 1. At this stage both methods are mathematically equivalent [22]. However, the topological-amplitude method has the advantage that it can be combined with large- N_c counting [23, 24] to sharpen the theoretical predictions. Here $N_c = 3$ is the number of colors and to leading order in the $1/N_c$ expansion the T and A amplitudes can be expressed in term of form factors and decay constants.

Armed with this formalism we can study branching fractions and CP asymmetries of $D \rightarrow PP'$ decays. These observables play very different roles in charm physics: Branching ratios of hadronic charm decays are “dull” tree-level quantities dominated by a single CKM amplitude and are therefore insensitive to new physics. They are useful to test the calculational framework and experimentally determine $|A_{sd}|$, which is one of the ingredients to predict CP asymmetries. On the contrary, CP asymmetries of hadronic charm decays are suppressed by $\text{Im} \frac{\lambda_b}{\lambda_{sd}} = -6 \cdot 10^{-4}$ in the Standard Model and therefore probe new physics in flavour transitions of up-type quarks. When exploiting the experimental information on 16 $D \rightarrow PP'$ branching fractions and the $D^0 \rightarrow K^\pm \pi^\mp$ strong-phase difference to predict CP asymmetries, one faces a fundamental problem: CP asymmetries involve topological amplitudes (equivalently, reduced $\text{SU}(3)_F$ amplitudes) which do not enter branching ratios and are therefore unconstrained by any global fit to the corresponding data. The most prominent example is the penguin amplitude: Denoting the penguin with internal

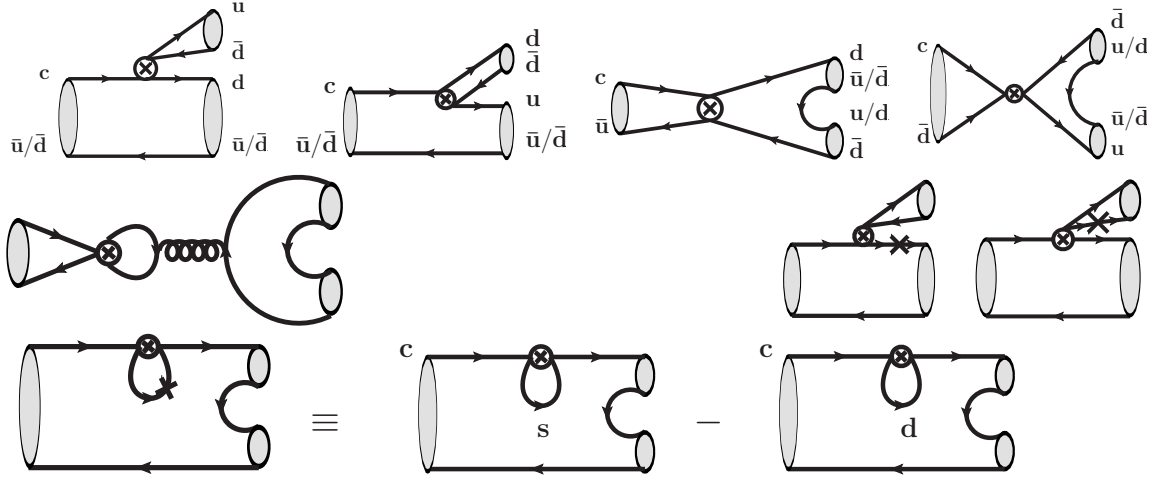

Figure 1: First row: $SU(3)_F$ limit topological amplitudes “tree” (T), “color-suppressed tree” (C), “exchange” (E), “annihilation” (A). Second row: penguin annihilation (PA) diagram and examples of topological amplitudes describing $SU(3)_F$ -breaking effects (with the cross distinguishing an s from a d or u line); the depicted diagrams are T_1 and T_2 . Third row: depiction of $P_{\text{break}} \equiv P_s - P_d$, which is also an $SU(3)_F$ -breaking amplitude.

quark q by P_q , the branching fractions only constrain the ($SU(3)_F$ -breaking) combination $P_{\text{break}} \equiv P_s - P_d$. CP asymmetries, however, involve not only P_{break} but also $P \equiv P_s + P_d - 2P_b$.

Since we cannot predict individual CP asymmetries, we may next try to predict relations (sum rules) between different CP asymmetries. In the limit of exact $SU(3)_F$ symmetry there are two sum rules among two direct CP asymmetries each [13]:

$$a_{CP}^{\text{dir}}(D^0 \rightarrow K^+ K^-) + a_{CP}^{\text{dir}}(D^0 \rightarrow \pi^+ \pi^-) = 0, \quad (2.1)$$

$$a_{CP}^{\text{dir}}(D^+ \rightarrow \bar{K}^0 K^+) + a_{CP}^{\text{dir}}(D_s^+ \rightarrow K^0 \pi^+) = 0. \quad (2.2)$$

In Ref. [17] it has been shown that there are no sum rules among CP asymmetries which hold to first order in $SU(3)_F$ breaking. Can we improve on Eqs. (2.1) and (2.2) anyway? To this end consider, for example,

$$A_{sd}(D^0 \rightarrow \pi^+ \pi^-) = -T - E + P_{\text{break}}, \quad A_b(D^0 \rightarrow \pi^+ \pi^-) = T + E + P + PA, \quad (2.3)$$

which entails $A_b(D^0 \rightarrow \pi^+ \pi^-) = -A_{sd}(D^0 \rightarrow \pi^+ \pi^-) + P_{\text{break}} + P + PA$. (PA is defined analogously to P .) Then Eq. (1.4) reads

$$a_{CP}^{\text{dir}}(D^0 \rightarrow \pi^+ \pi^-) = \text{Im} \frac{\lambda_b}{\lambda_{sd}} \text{Im} \frac{P_{\text{break}} + P + PA}{A_{sd}(D^0 \rightarrow \pi^+ \pi^-)}. \quad (2.4)$$

In the $SU(3)_F$ limit the corresponding expression for $a_{CP}^{\text{dir}}(D^0 \rightarrow K^+ K^-)$ is indeed equal in magnitude and opposite in sign. One can next use the global branching-ratio analysis of Ref. [22] to determine all ingredients of $a_{CP}^{\text{dir}}(D^0 \rightarrow \pi^+ \pi^-)$ and $a_{CP}^{\text{dir}}(D^0 \rightarrow K^+ K^-)$ including first-order $SU(3)_F$ breaking, except for $P + PA$ which is unconstrained. I.e. we are left with two quantities depending

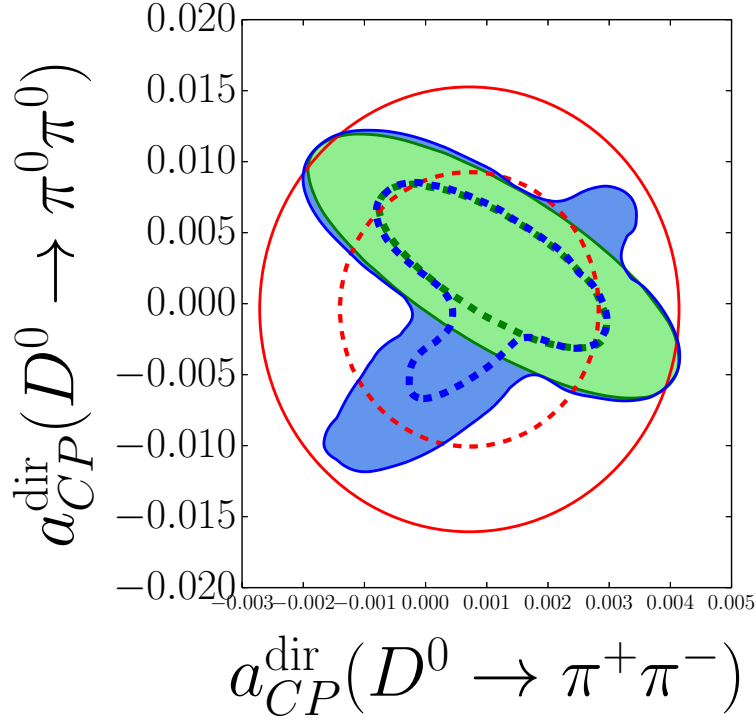

Figure 2: The solid (dashed) lines delimit the 95% (68%) CL region. Red: direct measurements. Blue: prediction of sum rule with present data. Green: sum rule if branching ratios were improved by a factor of $\sqrt{50}$ compared to today. Plot from Ref. [25].

on two unknowns, which are real and imaginary part of $P + PA$. In order to make a prediction we therefore need a third quantity, $a_{CP}^{\text{dir}}(D^0 \rightarrow \pi^0 \pi^0)$. By eliminating $P + PA$ we find the desired sum rule. The global fit à la Ref. [22] determines all topological amplitudes entering A_{sd} for the three decay modes (which are T , E , C , $T_{1,2}$, $E_{1,2}$, and P_{break}), so that the troublesome $SU(3)_F$ -breaking terms causing $B(D^0 \rightarrow K^+ K^-) \neq B(D^0 \rightarrow \pi^+ \pi^-)$ are taken care of. However, $P + PA$ cannot be treated beyond the $SU(3)_F$ limit. Fig. 2 shows the impact of the sum rule. Similarly, we can improve Eq. (2.2) to a sum rule involving also the third decay mode $D_s^+ \rightarrow K^+ \pi^0$. With current data the sum rule has much larger errors than the one for $D^0 \rightarrow K^+ K^-, \pi^+ \pi^-, \pi^0 \pi^0$.

3. CP asymmetry in $D^0 \rightarrow K_S K_S$

$D^0 \rightarrow K_S K_S$ has the special feature that A_{sd} vanishes in the $SU(3)_F$ limit. The smallness of $|A_{sd}|$ enhances A_b/A_{sd} , so that a_{CP}^{dir} in Eq. (1.4) is expected to be larger than in other decays. Concerning statistical errors this observation does not help, because the gain in statistical significance is cancelled by the smaller number of events, which scale with the branching ratio proportional to $|A_{sd}|^2$. In our case we have $B(D^0 \rightarrow K_S K_S) = (1.7 \pm 0.4) \cdot 10^{-4}$. Still, a larger CP asymmetry may help to fight systematic errors. Another special feature of the considered decay mode is way more interesting: The numerator A_b in Eq. (1.4) receives contributions from the exchange diagram E , so that the CP asymmetry persists even if the loop-induced amplitudes P and PA (which induce the CP asymmetries in essentially all other decay modes) turn out to be tiny. Moreover, the global fit

of Ref. [22] points to a large E and definitely excludes $E = 0$. The sensitivity to E stems from the feature that in $D^0 \rightarrow K_S K_S$ the transitions $c\bar{u} \rightarrow s\bar{s}$ and $c\bar{u} \rightarrow d\bar{d}$ can interfere, because both $s\bar{s}$ and $d\bar{d}$ can hadronize into a $K_S K_S$ pair. In Ref. [26] we find

$$-1.1 \cdot 10^{-2} \leq a_{CP}^{\text{dir}} \leq 1.1 \cdot 10^{-2}. \quad (3.1)$$

This number assumes that the CP asymmetry related to Kaon mixing is properly subtracted. Unfortunately, the global fit to all $D \rightarrow PP'$ data presently does not rule out that $|a_{CP}^{\text{dir}}|$ is much smaller than $1.1 \cdot 10^{-2}$. One source of uncertainty is the strong phase $\arg(A_b/A_{sd})$ which is currently unconstrained. To eliminate this source of uncertainty, one must also measure the mixing-induced CP asymmetry [26], with a time-dependent measurement or through CP-tagged decays. Currently experiments determine

$$A_{CP} = a_{CP}^{\text{dir}} - A_{\Gamma} \frac{\langle t \rangle}{\tau}, \quad (3.2)$$

where $\langle t \rangle$ is the average decay time and τ is the D^0 lifetime. A_{Γ} involves the mixing-induced CP asymmetry and is small, because D^0 mesons oscillate very slowly. The experimental results are [27–29]

$$\begin{aligned} A_{CP}^{\text{CLEO 2001}} &= -0.23 \pm 0.19, & A_{CP}^{\text{LHCb 2015}} &= -0.029 \pm 0.052 \pm 0.022, \\ A_{CP}^{\text{Belle 2016}} &= -0.0002 \pm 0.0153 \pm 0.0017. \end{aligned}$$

4. Summary

CP asymmetries in D decays involve topological amplitudes which are not constrained by fits to branching ratio data. These can be eliminated by forming judicious combinations (sum rules) of several CP asymmetries. Within the limits of expected $SU(3)_F$ breaking in penguin (and penguin annihilation) amplitudes these sum rules probe new physics. Within the Standard Model the direct CP asymmetry in $D^0 \rightarrow K_S K_S$ can be as large as 1.1%. $a_{CP}^{\text{dir}}(D^0 \rightarrow K_S K_S)$ is dominated by the exchange diagram, which involves no loop suppression. We advocate $D^0 \rightarrow K_S K_S$ as a potential discovery channel for charm CP violation.

Acknowledgements

I thank the organisers for inviting me to this talk. The presented work is supported by BMBF under contract 05H12VKF. Parts of the computations were performed on the NEMO cluster of Baden-Württemberg (framework program bwHPC).

References

- [1] G. Hiller, M. Jung and S. Schacht, Phys. Rev. D **87** (2013) no.1, 014024 doi:10.1103/PhysRevD.87.014024 [arXiv:1211.3734 [hep-ph]].
- [2] E. Franco, S. Mishima and L. Silvestrini, JHEP **1205** (2012) 140 doi:10.1007/JHEP05(2012)140 [arXiv:1203.3131 [hep-ph]].

- [3] H. n. Li, C. D. Lu and F. S. Yu, Phys. Rev. D **86** (2012) 036012 doi:10.1103/PhysRevD.86.036012 [arXiv:1203.3120 [hep-ph]].
- [4] J. Brod, Y. Grossman, A. L. Kagan and J. Zupan, JHEP **1210** (2012) 161 doi:10.1007/JHEP10(2012)161 [arXiv:1203.6659 [hep-ph]].
- [5] T. Feldmann, S. Nandi and A. Soni, JHEP **1206** (2012) 007 doi:10.1007/JHEP06(2012)007 [arXiv:1202.3795 [hep-ph]].
- [6] H. Y. Cheng and C. W. Chiang, Phys. Rev. D **85** (2012) 034036 Erratum: [Phys. Rev. D **85** (2012) 079903] doi:10.1103/PhysRevD.85.079903, 10.1103/PhysRevD.85.034036 [arXiv:1201.0785 [hep-ph]].
- [7] D. Pirtskhalava and P. Uttayarat, Phys. Lett. B **712** (2012) 81 doi:10.1016/j.physletb.2012.04.039 [arXiv:1112.5451 [hep-ph]].
- [8] J. Brod, A. L. Kagan and J. Zupan, Phys. Rev. D **86** (2012) 014023 doi:10.1103/PhysRevD.86.014023 [arXiv:1111.5000 [hep-ph]].
- [9] I. I. Bigi, A. Paul and S. Recksiegel, JHEP **1106** (2011) 089 doi:10.1007/JHEP06(2011)089 [arXiv:1103.5785 [hep-ph]].
- [10] M. Bobrowski, A. Lenz, J. Riedl and J. Rohrwild, JHEP **1003** (2010) 009 doi:10.1007/JHEP03(2010)009 [arXiv:1002.4794 [hep-ph]].
- [11] A. A. Petrov, PoS BEAUTY **2009** (2009) 024 [arXiv:1003.0906 [hep-ph]].
- [12] M. Artuso, B. Meadows and A. A. Petrov, Ann. Rev. Nucl. Part. Sci. **58** (2008) 249 doi:10.1146/annurev.nucl.58.110707.171131 [arXiv:0802.2934 [hep-ph]].
- [13] Y. Grossman, A. L. Kagan and Y. Nir, Phys. Rev. D **75** (2007) 036008 doi:10.1103/PhysRevD.75.036008 [hep-ph/0609178].
- [14] F. Buccella, M. Lusignoli, G. Miele, A. Pugliese and P. Santorelli, Phys. Rev. D **51** (1995) 3478 doi:10.1103/PhysRevD.51.3478 [hep-ph/9411286].
- [15] M. Golden and B. Grinstein, Phys. Lett. B **222** (1989) 501. doi:10.1016/0370-2693(89)90353-5
- [16] Y. Grossman and D. J. Robinson, JHEP **1304** (2013) 067 doi:10.1007/JHEP04(2013)067 [arXiv:1211.3361 [hep-ph]].
- [17] Y. Grossman, Z. Ligeti and D. J. Robinson, JHEP **1401** (2014) 066 doi:10.1007/JHEP01(2014)066 [arXiv:1308.4143 [hep-ph]].
- [18] L. L. C. Wang, *Flavor Mixing and Charm Decay*, talk at the Conference on Theoretical Particle Physics, 5-14 January 1980, Guangzhou (Canton), China, p. 1218, report BNL-27615, C80-01-05-20.
- [19] L. L. Chau, Phys. Rept. **95** (1983) 1. doi:10.1016/0370-1573(83)90043-1
- [20] D. Zeppenfeld, Z. Phys. C **8** (1981) 77. doi:10.1007/BF01429835
- [21] M. Gronau, O. F. Hernandez, D. London and J. L. Rosner, Phys. Rev. D **52** (1995) 6356 doi:10.1103/PhysRevD.52.6356 [hep-ph/9504326].
- [22] S. Müller, U. Nierste and S. Schacht, Phys. Rev. D **92** (2015) no.1, 014004 doi:10.1103/PhysRevD.92.014004 [arXiv:1503.06759 [hep-ph]].
- [23] A. J. Buras, J. M. Gerard and R. Ruckl, Nucl. Phys. B **268** (1986) 16. doi:10.1016/0550-3213(86)90200-2

- [24] A. J. Buras and L. Silvestrini, Nucl. Phys. B **569** (2000) 3 doi:10.1016/S0550-3213(99)00712-9 [hep-ph/9812392].
- [25] S. Müller, U. Nierste and S. Schacht, Phys. Rev. Lett. **115** (2015) no.25, 251802 doi:10.1103/PhysRevLett.115.251802 [arXiv:1506.04121 [hep-ph]].
- [26] U. Nierste and S. Schacht, Phys. Rev. D **92** (2015) no.5, 054036 doi:10.1103/PhysRevD.92.054036 [arXiv:1508.00074 [hep-ph]].
- [27] G. Bonvicini *et al.* [CLEO Collaboration], Phys. Rev. D **63** (2001) 071101 doi:10.1103/PhysRevD.63.071101 [hep-ex/0012054].
- [28] R. Aaij *et al.* [LHCb Collaboration], JHEP **1510** (2015) 055 doi:10.1007/JHEP10(2015)055 [arXiv:1508.06087 [hep-ex]].
- [29] A. Abdesselam *et al.*, *Measurement of CP asymmetry in the $D^0 \rightarrow K_S^0 K_S^0$ decay at Belle*, talk at *38th International Conference on High Energy Physics (ICHEP2016)*, 3-10 August 2016, Chicago, USA, arXiv:1609.06393 [hep-ex].