

Experimental string with fiber optic data acquisition for Baikal-GVD

V.A. Allakhverdyan¹, A.D. Avrorin², A.V. Avrorin², V.M. Aynutdinov^{2,*}, R. Bannasch³, Z. Bardačová⁴, I.A. Belolaptikov¹, I.V. Borina¹, V.B. Brudanin¹, N.M. Budnev⁵, V.Y. Dik¹, G.V. Domogatsky², A.A. Doroshenko², R. Dvornický^{1,4}, A.N. Dyachok⁵, Zh.-A.M. Dzhilkibaev², E. Eckerová⁴, T.V. Elzhov¹, L. Fajt⁶, S.V. Fialkovsky⁷, A.R. Gafarov⁵, K.V. Golubkov², N.S. Gorshkov¹, T.I. Gress⁵, M.S. Katulin¹, K.G. Kebkal³, O.G. Kebkal³, E.V. Khramov¹, M.M. Kolbin¹, K.V. Konischev¹, K.A. Kopański⁸, A.V. Korobchenko¹, A.P. Koshechkin², V.A. Kozhin⁹, M.V. Kruglov¹, M.K. Kryukov², V.F. Kulepov⁷, Pa. Malecki⁸, Y.M. Malyshkin¹, M.B. Milenin², R.R. Mirgazov⁵, D.V. Naumov¹, V. Nazari¹, W. Noga⁸, D.P. Petukhov², E.N. Pliskovsky¹, M.I. Rozanov¹⁰, V.D. Rushay¹, E.V. Ryabov⁵, G.B. Safronov², B.A. Shaybonov¹, M.D. Shelepov², F. Šimkovic^{1,4,6}, A.E. Sirenko¹, A.V. Skurikhin⁹, A.G. Solovjev¹, M.N. Sorokovikov¹, I. Štek⁶, A.P. Stromakov², E.O. Sushenok¹, O.V. Suvorova², V.A. Tabolenko⁵, B.A. Tarashansky⁵, Y.V. Yablokova¹, S.A. Yakovlev³, and D.N. Zaborov²

¹ Joint Institute for Nuclear Research, Dubna, Russia, 141980

² Institute for Nuclear Research, Russian Academy of Sciences, Moscow, Russia, 117312

³ EvoLogics GmbH, Berlin, Germany, 13355

⁴ Comenius University, Bratislava, Slovakia, 81499

⁵ Irkutsk State University, Irkutsk, Russia, 664003

⁶ Czech Technical University in Prague, Prague, Czech Republic, 16000

⁷ Nizhny Novgorod State Technical University, Nizhny Novgorod, Russia, 603950

⁸ Institute of Nuclear Physics of Polish Academy of Sciences (IFJ PAN), Krakow, Poland, 60179

⁹ Skobeltsyn Institute of Nuclear Physics MSU, Moscow, Russia, 119991

¹⁰ St. Petersburg State Marine Technical University, St. Petersburg, Russia, 190008

*E-mail: aynutdin@yandex.ru

The first stage of the construction of the deep underwater neutrino telescope Baikal-GVD is planned to be completed in 2024. The second stage of the detector deployment is planned to be carried out using a data acquisition system based on fiber optic technologies, which will allow for an increased data throughput and more flexible trigger conditions, thus maximizing the neutrino detection efficiency. A dedicated experimental string has been built and deployed at the Baikal-GVD site to test the new technological solutions. We present the principle of operation and preliminary results of in-situ tests of the experimental string.

37th International Cosmic Ray Conference (ICRC 2021)

July 12th – 23rd, 2021

Online – Berlin, Germany

*Presenter

© Copyright owned by the author(s) under the terms of the Creative Commons Attribution-NonCommercial-NoDerivatives 4.0 International License (CC BY-NC-ND 4.0).

<https://pos.sissa.it/>

1. Introduction

The large-scale neutrino telescope Baikal-GVD [1, 2] is under construction now. The beginning of the deployment of the telescope dates back to 2016, when the first cluster of the installation, which includes 288 photodetectors - optical modules (OM), was put into operation. By 2021, eight such clusters have been commissioned, and Baikal-GVD is currently the largest neutrino telescope in the Northern hemisphere. In the next three years, it is planned to increase the number of clusters to 14, covering a total effective volume of about 0.7 km^3 for the registration of astrophysical neutrinos. Given the general trends in the development of neutrino telescopes in the direction of a qualitative increase in their effective volume to the scale of $\sim 10 \text{ km}^3$ on the one hand and an increase in the density of photodetector placement on the other, further development of the Baikal-GVD project will require reconfiguration of the detector measuring system. In addition, changing priorities and the emergence of new physical tasks require the ability to adapt trigger selection algorithms. The deployment conditions of the installation from the lake ice cover provides unique opportunities for reconfiguration, up to changing the arrangement of the strings without dismantling them. At the same time, the Baikal-GVD data acquisition system imposes a number of restrictions on the implementation of new installation configurations. This is due to both the relatively low speed of information transmission from the detector's measuring system and not enough flexible algorithms of the trigger system of the installation.

A drastic way to solve this problem is to modernize the data acquisition system (DAQ) based on fiber-optic technologies. The implementation of this seemingly obvious approach requires a significant amount of research work. While electronic equipment based on optical technologies has now become available in industrial design, the possibilities of using ready-made solutions for deep-underwater fiber-optic cable systems are quite limited. This article discusses the general approaches to solving the problem of modernization of the Baikal-GVD data acquisition system with fiber-optic technologies and presents the first technical solutions, which are currently being tested in situ as part of the experimental string of the neutrino telescope.

2. General approaches to DAQ design

The Baikal-GVD data acquisition system [3] has a hierarchical structure. Optical modules developed on the basis of the PMT R7081-100 are used as the telescope's photodetectors [4, 5]. The optical modules of the installation are grouped in *sections* of 12 OM. The processing of analog signals coming from the OM is carried out in the central module of the section, which forms a local trigger and generates event time frames. Three *sections* form a *string*. The data from the sections is transmitted to the string control modules, which, in turn, transmit it to the data collection center of the *cluster*, located near the surface of the lake. Cluster includes 8 *strings*. The optical modules are located on the *strings* at a depth of 1275 to 750 meters. The arrangement scheme of the OMs in a string consisting of three sections is shown in Fig. 2.1.

Information is exchanged on all the segments of underwater network (section – string – cluster center) via Ethernet extenders, which limit the data transfer rate to about 6 Mbit/s. In turn, it limits the maximum frequency of the cluster triggers at about 200 Hz and, accordingly, the trigger thresholds of the channels. Currently, the cluster trigger is formed if the signals from

two neighboring OMs of any section coincide in the time window of 100 ns. The values of the trigger thresholds that provide the counting rate within the specified limit are ~ 1.5 and 4 photoelectrons (pe). A theoretical calculation suggests that the reduction of the trigger threshold to 1-pe level results in an improvement of the efficiency for recording of events by a factor of about three near the energy threshold. At the same time, increasing the number of sections on the string will lead to an even greater increase in trigger thresholds.

To increase the capacity of the DAQ, the possibility of its upgrade based on fiber-optic communication is currently being investigated. In addition, the reduction of the detection thresholds, the fiber-optic communication has a number of other advantages associated with the increased stability and reliability (in particular, it is not sensitive to lightning discharges occurring near the installation). The faster speed of underwater data network will allow increasing the number of sections and optical modules in a string, leading to a configuration with a denser arrangement of OMs. The optical channels can be used not only to transmit data, but also to send the synchronization and trigger messages.

The design of the optical DAQ includes components associated with all basic elements of the detector, which are *sections*, *strings* and *clusters* of optical modules. The design aims at providing an optic-fiber communication solution for the data stream, as well as trigger and sync signals. Another important requirement was the use of detachable optical connectors for underwater optical cables and minimization of their number, which is due to the technical conditions for the deployment of the strings from the ice of the lake.

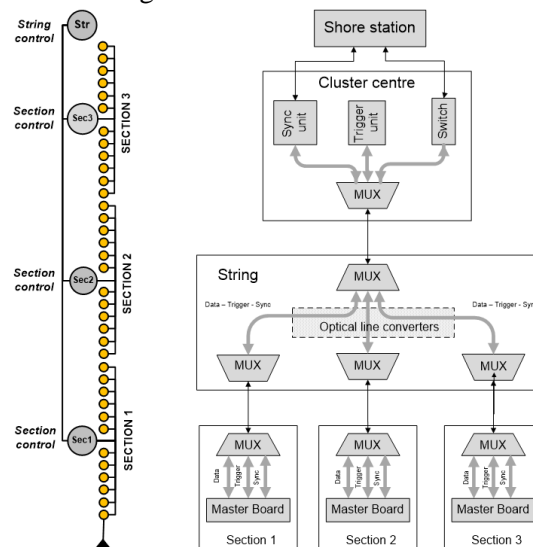

Fig. 2.1. Baikal-GVD string and the general principle of the organization of the string DAQ based on optical multiplexers.

For the DAQ implementation the CWDM technology (Coarse Wavelength Division Multiplexing) has been chosen, which is now widely used in the building of fiber-optic systems. CWDM multiplexers are passive devices that allow to organize up to 9 physical channels on a single fiber using the frequency division method. This approach makes it possible to transmit all information (the data stream, trigger, and sync) over a single optical fiber, which allows to limit each segment of the underwater network to one fiber-optic line. The principle of building a string DAQ is presented in Fig. 2.1. The section control modules are equipped with CWDM multiplexers (MUX) that form three physical channels in a single optical fiber: *data*, *trigger*,

and *sync*. Through these channels, information is transmitted to the string control module. It is possible to form nine channels in one fiber (three for each section) without using additional electronics devices in the string module. This approach requires a minimum number of active optical components, but it also has a number of disadvantages. First, it is a loss of unification: the control modules of the sections use different wavelengths for communication and become not interchangeable. Secondly, the number of communications and active electronic components in the modules of the cluster center reaches a level at which the heat removal from the underwater enclosures becomes critical. And, most importantly, the number of sections on the string cannot exceed three, which is due to the restriction of the CWDM system on the number of physical channels on a single optical fiber. Therefore, another option is considered, in which data, trigger and sync channels of the sections are combined in the string module using active electronic units. The simplest example of such unit for a data channel is an Ethernet switch with several optical ports. The information from the string goes to the cluster center, where the trigger signals are analyzed (*Trigger unit*), a common clock frequency for the strings is formed (*Sync unit*), and the data from all strings is combined on the Ethernet Switch. Data and synchronization signals are transmitted to the Shore station via a hybrid cable that comprises 6 optical fibers and power wires.

3. Experimental section

In order to test experimentally the possibilities of using CWDM technology to build the Baikal-GVD DAQ, an experimental section based on a fiber-optic data transmission system was installed in the telescope in 2020. The section included 12 optical modules (OM), two acoustic modems (AM) of the positioning system [6], and a central control module (see Fig. 3.1). To use all advantages of the high-speed optical transmission, the data acquisition unit of the section module (*Master*) was upgraded on the basis of FPGA Xilinx Zynq. The increase in the memory size and processing power of the *Master* made it possible to organize a multi-trigger system with an extended range of time window for the trigger generation: up to 20 ms. Information was transmitted from the section directly to the Shore station via a single fiber-optic line using a 4-channel CWDM multiplexer with the wavelength range from 1310 nm to 1450 nm (8 wavelength with 20 nm step). NS-SFP 1.25G CWDM optical transceivers (SFP modules), 80 km range, were used for data transmission. The lower part of Fig. 3.1 shows a schematic diagram of the organization of the transmission system.

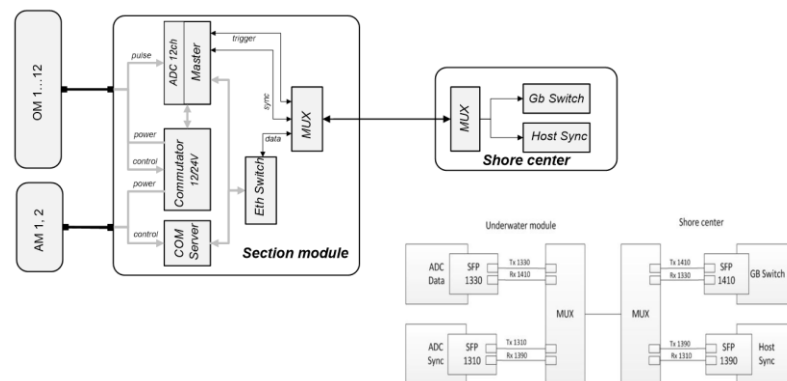

Fig. 3.1. The block diagram of the experimental section and the organization of the data transmission.

The data transmission from the *Master* unit (ADC Data) was carried out at wavelength of 1330 nm via an SFP module and a channel of optical multiplexer MUX with the appropriate wavelength. This information was transmitted to the Shore Ethernet switch via a similar multiplexer and an SFP module with a wavelength of 1410 nm, on which data was transmitted in the opposite direction. The synchronization pulses were transmitted to the *Master* at wavelength of 1390 nm by the Shore synchronization unit *HOST*. Receiving of synchronization data from the *Master* for measuring the optical line delay was carried out at a wavelength of 1310 nm. The total length of the optical line was about 7 km. It consisted of two segments. The section segment (about 1 km long) was connected to the section module and the cluster center via optical underwater connectors. The cluster, in turn, was connected to the Shore center via a 6-kilometer optical cable without the use of detachable underwater optical connectors.

The experimental section was tested during 2020 in the mode of operation with two joint triggers: the coincidence of signals from neighboring optical modules (the *fast* trigger) and a jump-like increase in the pulse counting rate of the optical modules (the *slow* trigger). In the second case, the trigger was formed when the counting rate of any channel of the section exceeding during 1 ms the average rate by 4 standard deviations. This version of the trigger is focused on the selection of time-extended events, in particular, the registration of *slow monopoles* (the trajectory of the slow monopole at the intersection of the water volume should look like a "chain" of flashes resulting from the reactions of monopole catalysis of baryon decay).

In the *fast trigger* mode, in particular, the reliability of the data transmission system was studied depending on the trigger thresholds. The main characteristic of the reliability of the system is the fraction of lost events in the transmitted data stream. Table 3.1 shows the fraction of lost events depending on the trigger thresholds and, accordingly, the rate of trigger generation. At the minimum single-photoelectronic thresholds, the fraction of lost events does not exceed one hundredth of a percent. In the *slow trigger* mode, the ambient light background of Lake Baikal (the average value and fluctuations depending on the depth and season) is investigated. During the year of the section operation, no malfunctions of the section operation were detected.

Table 3.1. Reliability of the data transmission system at different trigger thresholds.

Trigger threshold, pe.	Trigger rate, Hz	Baud rate, Kbyte/s	Lost events, %
1.5 & 3.5	5.2	2.8	0
1.5 & 3.0	5.7	3.2	0
1.5 & 2.5	6.5	3.8	0
1.5 & 2.0	7.5	4.4	0
1.5 & 1.5	14	8.7	0
1.0 & 1.5	205	123	0.0002
1.0 & 1.0	1167	681	0.009

4. Experimental string

The successful operation of the experimental section made it possible to start testing the experimental string, which is a full-scale prototype of the basic string of Baikal-GVD. In April

2021 the string was installed in Lake Baikal. The block diagram of the experimental string is shown in Fig. 4.1.

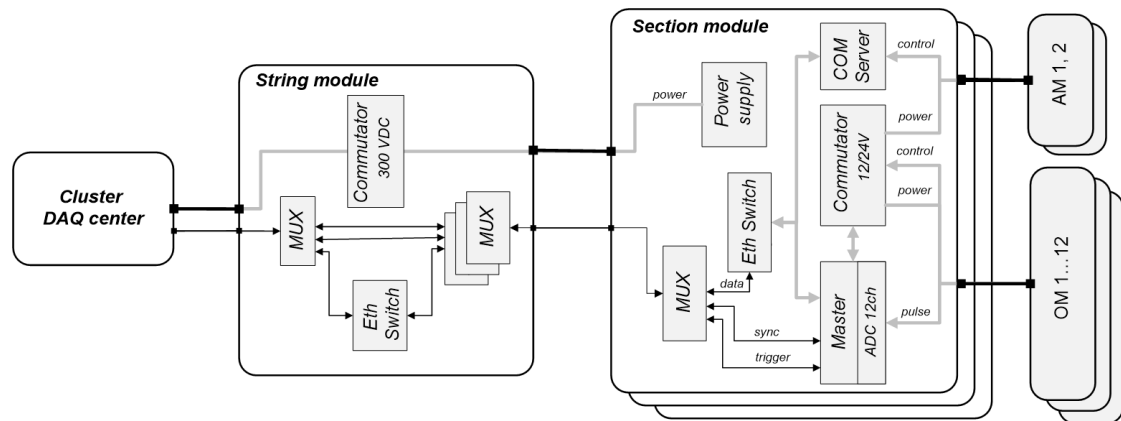

Fig. 4.1. Block diagram of the experimental string.

The experimental string consists of three sections, a string control module and an optical cluster center. The construction of the sections is similar to the experimental section (see Fig. 3.1). The control modules of the sections are each connected to the string control module by two separate cables: an optical one with a single fiber and an electric one for the power supply. The fiber optic cables are equipped with underwater optical connectors. The signals received from the OMs are processed in the *Master* unit, which is equipped with a 12-channel ADC with a sampling rate of 200 MHz. The *Master* forms two optical channels (*trigger* and *sync*) and one electrical channel (Gigabit Ethernet), which is converted to optical using an Ethernet switch. The OMs and AMs of the section are controlled via a 16-channel power switch and a COM Server (MOXA NPort 5250). The input voltage of 300 VDC is supplied to the section control module via two independent lines: one is used to control electronics power supply, the second one provides power for OMs and AMs. In the string module, the data channels of the three sections are combined into one on the Ethernet switch. Therefore, each of the three sections in a string have a total of seven physical channels, one for data, three for trigger, and three for synchronization message. The data transmission via these channels to the cluster DAQ center is carried out via a CWDM multiplexer over a single optical fiber. The distribution of channels for the three sections by wavelengths is shown in Table 4.1.

Table 4.1. Distribution of the channels of the three sections by CWDM wavelengths, T – the transmitter, R – the receiver.

Channels	Data	Trigger	Sync
Section 1: T / R, nm	1310 / 1330	1350 / 1370	1390 / 1410
Section 2: T / R, nm	1310 / 1330	1430 / 1450	1470 / 1490
Section 3: T / R, nm	1310 / 1330	1510 / 1530	1550 / 1570

The experimental string started operation on 8 April 2021 in the mode of operation of two joint triggers, similar to the experimental section of 2020. The *fast trigger* initiated reading of information from all sections of the string, while the *slow trigger* operated only for the section that formed it. Currently, the main task of investigations with the experimental string is to evaluate the efficiency and reliability of the operation of the fiber-optic DAQ: both electronic components and underwater cable network.

5. Underwater cable network

There are two types of fiber-optic (FO) cable lines used for the experimental string (see Fig. 5.1). Most of the connections are made by commercial cable assemblies manufactured by DWTEK Co., Ltd, Taiwan. The Bulkhead Connector Receptacle (BCR) MSS-OP-BCR were used in combination with the cable connectors MSS-OP-CCP, installed on a radially sealed underwater FO cable manufactured by the same company (DWTEK MO1-I01590/OPY402 900um). The permissible immersion depth of the assembled cable line, according to the specification, is 6000 m, the insertion loss in the connector does not exceed 0.5 dB. Experimental string comprises of 5 such cable lines with different lengths from 3 to 750 m. To install the BCR in the openings of the glass sphere of the underwater modules, special stainless adapters were used to securely fix the connector and reduce the local pressure on the glass surface. One of the three sections (upper section #3) is connected to the string using the experimental development of the Russian enterprise NPP "Starlink". The connectors are designed to meet the technical requirements of the Baikal neutrino telescope. A deep-water radially sealed armored FO cable of the original design with length of 95 m was used.

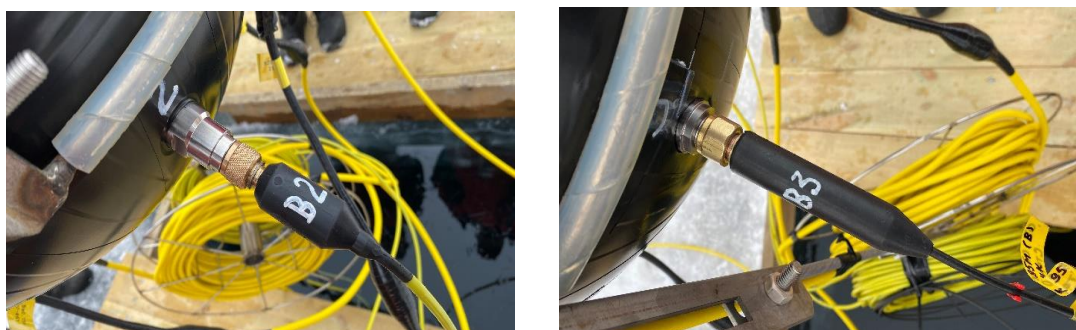

Fig. 5.1. Cable connector assemblies mounted on the glass body of the deep-water module of the experimental string: *DWTEK* (left), *Starlink* (right).

The main condition for reliable optical communication is a low level of signal attenuation in fiber optic lines. To monitor this parameter, the power measurement function of transmitters and receivers built into the SFP modules was used. The threshold power of the NS-SFP 1.25 G CWDM optical transceivers used in the experimental string is -23 dBm (a signal with a power of 1 mW corresponds to 0 dBm). Fig. 5.2 shows the time dependence of power of transmitters and receivers of the SFP modules of the *trigger* and *synchronization* channels for two sections of the string during one month of operation. The *trigger* and *synchronization* channels connect the sections to the cluster center without intermediate electronic amplification, and their attenuation is most essential for the reliable operation of the DAQ. The sources of power loss in these channels are 4 serially connected CWDM multiplexers and 6 underwater optical connectors. The power attenuation in these channels is about 10 dB. The signal power exceeds the threshold value of the receivers by more than 10 dB. At the same time, there are fluctuations in the power of the received signals, and the study of the causes of the increasing loss is one of the priority tasks of the testing of the experimental set-up.

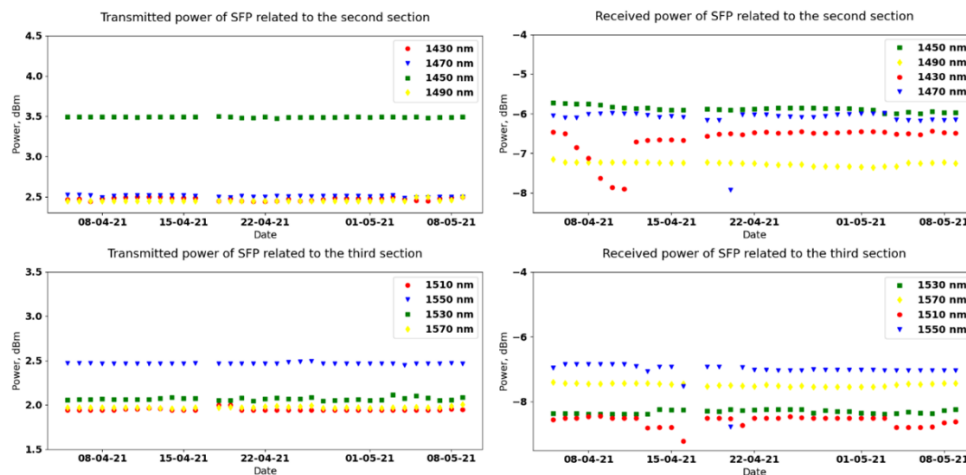

Fig. 5.2. Time dependence of the power of the transmitters (left) and receivers (right) of optical transceivers for the 2-nd (*DWTEK* cable) and the 3-rd (*Starlink* cable) sections.

6. Conclusion

To improve the efficiency of Baikal-GVD and expand the possibility of reconfiguring its measurement system, research is being conducted on the possibilities of upgrading the data acquisition system on the basis of fiber optic communication. The first successful experience of such a system was obtained in 2020, when the experimental section with the upgraded DAQ was put into operation. In 2021, the research was continued and the experimental string, which includes three sections (36 OMs), was installed in Lake Baikal. In general, it is already possible to make a conclusion about the prospects of implementing a fiber-optic communication system based on CWDM technology at the Baikal-GVD. However, the problems associated with providing the installation with reliable deep-water optical cables have not been completely solved. In 2022, it is planned to continue research in this direction on the basis of additional experimental strings, which are planned to be installed in Lake Baikal. It is also planned to develop additional electronic systems that allow combining the channels of the trigger and synchronization of the sections. The work was partially supported by RFBR grants 20-02-00400 and 19-29-11029.

References

- [1] I.A. Belolaptikov et al. (Baikal Collaboration), *The Baikal underwater neutrino telescope: Design, performance, and first results*, *Astropart. Phys.* **7** (1997) 263.
- [2] A.V. Avrorin et al. (Baikal Collaboration), *The Gigaton volume detector in lake Baikal*, *Nucl. Instr. and Meth. in Phys. Res. A*, **639** (2011) 30.
- [3] V.M. Aynutdinov et al. (Baikal Collaboration), *The data acquisition system for Baikal-GVD*, *EPJ Web of Conferences*, **116** (2016) 5004.
- [4] A.D. Avrorin et al. (Baikal Collaboration), *The optical module of Baikal-GVD*, *EPJ Web of Conferences*, **116** (2016) 01003.
- [5] A.D. Avrorin et al. (Baikal Collaboration), *The optical detection unit for Baikal-GVD neutrino telescope*, *EPJ Web of Conferences*, **121** (2016) 05008.
- [6] A.D. Avrorin et al. (Baikal Collaboration), *Spatial positioning of underwater components for Baikal-GVD*, *EPJ Web of Conf.* **207** (2019) 07004.